

Venus838LPx-T

Timing Mode GPS Receiver

Data Sheet

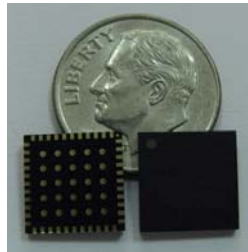

10mmx 10mm

Venus838LPx-T-L / Venus838LPx-T-D

FEATURES

- Complete GPS receiver module in 10 x 10 x 1.3 mm
- -148dBm cold start sensitivity
- -165dBm tracking sensitivity
- 29 second cold start TTFF
- 3.5 second TTFF with AGPS
- 1 second hot start
- 2.5m accuracy
- Multipath detection and suppression
- Jamming detection and mitigation
- QZSS and SBAS support
- 6nsec (1-sigma) timing accuracy
- Position hold mode for GPS timing operation
- 1PPS generation with 1 satellite in view
- 10MHz output phase-locked to 1PPS
- 0.8mm pitch LGA69 package, RoHS compliant

Venus838LPx-T is a high performance, low cost, single chip GPS receiver targeting precision timing applications. It offers very low power consumption, high sensitivity, and best in class signal acquisition and time-to-first-fix performance.

Venus838LPx-T contains all the necessary components of a complete GPS receiver, includes 1.2dB cascaded system NF RF front-end, GPS baseband signal processor, 0.5ppm TCXO, 32.768kHz RTC crystal, RTC LDO regulator, and passive components. It requires very low external component count and takes up only 100mm² PCB footprint.

Dedicated massive-correlator signal parameter search engine within the baseband enables rapid search of all the available satellites and acquisition of very weak signal. An advanced track engine allows weak signal tracking and positioning in harsh environments such as urban canyons and under deep foliage.

The self-contained architecture keeps GPS processing off the host and allows integration into applications with very little resource.

Venus838LPx-T is very easy to use, minimizes RF layout design issues and offers very fast time to market.

Product Series	Product Description
Venus838LPx-T-L	Timing mode GPS receiver module (internal 1.2V LDO version) Suitable for Venus638LPx-T-L direct drop-in replacement
Venus838LPx-T-D	Timing mode GPS receiver module (external 1.2V version) Suitable for lower power application using external 1.2V supply Suitable for Venus638LPx-T-D direct drop-in replacement

TECHNICAL SPECIFICATIONS

Receiver Type	L1 C/A code GPS QZSS SBAS 167 channel Venus 8 engine																									
Accuracy	Position	2.5m CEP																								
	Velocity	0.1m/sec																								
	Time	6nsec (1-sigma) < 12nsec (99%)																								
Open Sky TTFF	Hot start 1 second Cold start 29 seconds average																									
Reacquisition	< 1s																									
Sensitivity	Tracking -165dBm																									
Update Rate	1Hz standard																									
Dynamics	4G																									
Operational Limits	Altitude < 18,000m ^{*1} or Velocity < 515m/s ^{*1}																									
Datum	Default WGS-84																									
Interface	UART LVTTTL level																									
Baud Rate	4800 / 9600 / 38400 / 115200 software configurable (9600 as default)																									
Protocol	NMEA-0183 V3.01, GGA, GLL, GSA, GSV, RMC, VTG, ZDA SkyTraq Binary																									
Main Supply Voltage	2.8V ~ 3.6V	(Venus838LPx-T-L)																								
	2.8V ~ 3.6V, 1.08V ~ 1.32V	(Venus838LPx-T-D)																								
Backup Voltage	2.5V ~ 3.6V																									
Current Consumption (3.3V)	<table border="1"> <thead> <tr> <th></th> <th colspan="4">Acquisition</th> <th>Tracking</th> </tr> <tr> <th>Number of Search Engine</th> <th>2</th> <th>4</th> <th>6*</th> <th>8</th> <th></th> </tr> </thead> <tbody> <tr> <td>Venus838LPx-T-L</td> <td>39mA</td> <td>45mA</td> <td>51mA</td> <td>59mA</td> <td>33mA</td> </tr> <tr> <td>Venus838LPx-T-D**</td> <td>20mA</td> <td>23mA</td> <td>26mA</td> <td>30mA</td> <td>16mA</td> </tr> </tbody> </table>			Acquisition				Tracking	Number of Search Engine	2	4	6*	8		Venus838LPx-T-L	39mA	45mA	51mA	59mA	33mA	Venus838LPx-T-D**	20mA	23mA	26mA	30mA	16mA
	Acquisition				Tracking																					
Number of Search Engine	2	4	6*	8																						
Venus838LPx-T-L	39mA	45mA	51mA	59mA	33mA																					
Venus838LPx-T-D**	20mA	23mA	26mA	30mA	16mA																					
	* default 6 search engine used																									
	** 90% efficiency 3.3V-to-1.2V switch-mode regulator is used																									
Operating Temperature	-40 ~ +85 deg-C																									
Storage Temperature	-40 ~ +125 deg-C																									
Package	LGA69 10mm x 10mm x 1.3mm, 0.8mm pitch																									
Weight	0.3g																									

*1: COCOM limit, either may be exceeded but not both

BLOCK DIAGRAM

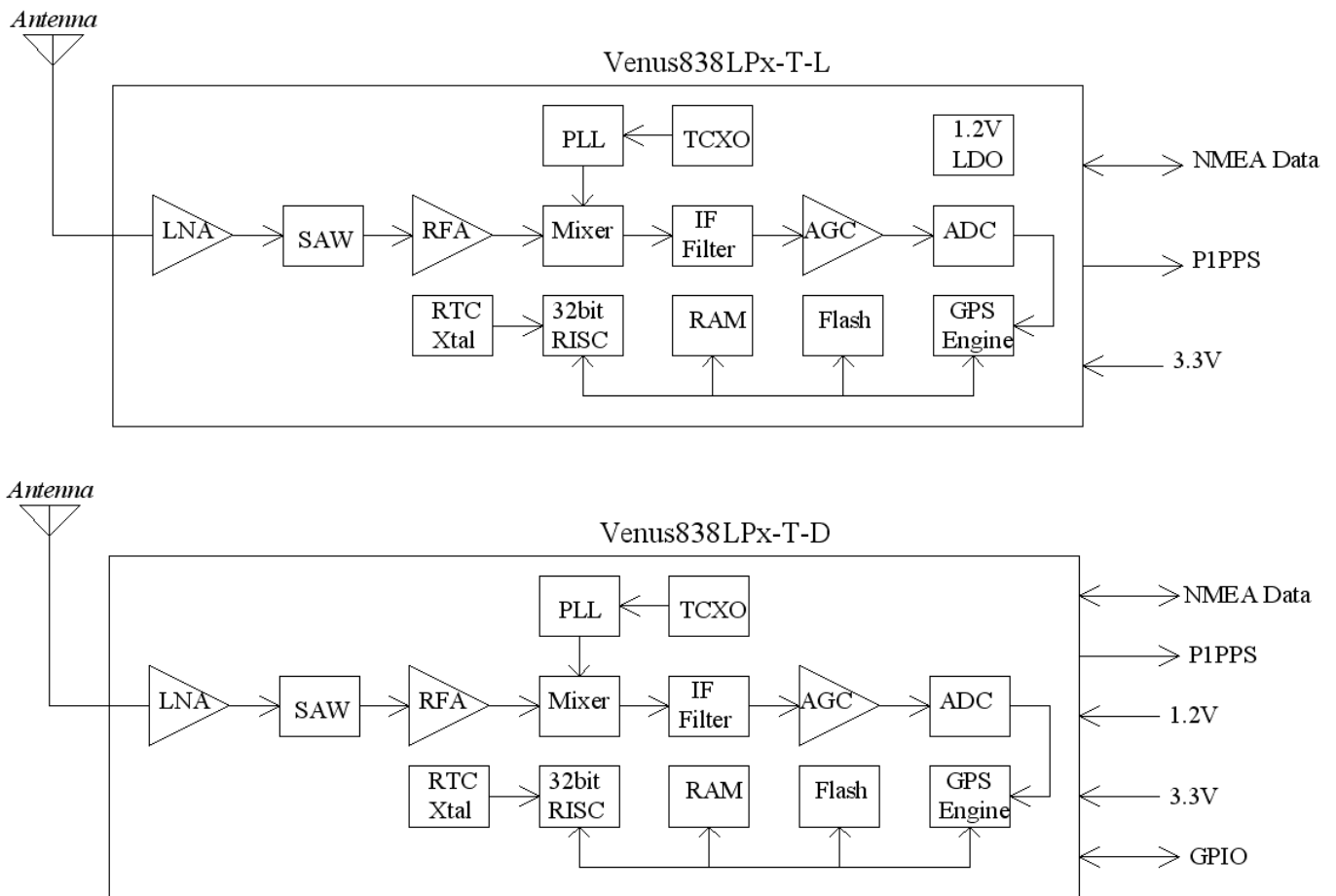

Figure-1 GPS Receiver based on Venus838LPx-T

OPERATION

When Venus838LPx-T is turned on, it automatically begin to acquire and track GPS signals. After valid ephemeris data is collected for each tracked satellite signal and ready for position fix, it performs self-survey of its location in Survey Mode. After 2000 position fixes (configurable) the Venus838LPx-T automatically enters Static Mode, a clock over-determined time-only mode.

Satellites above elevation mask and signal level above CNR mask are used for position fix. Default elevation mask is 5 degrees and CNR mask is 0.

Venus838LPx-T operates Survey Mode, Static Mode, or PVT Mode.

Upon power on, the Venus838LPx-T performs 2000 point position fix self-survey. The number of points used for self-survey may be changed using binary command 0x43. After self-survey is completed, the receiver enters Static Mode.

Static Mode is used in static timing application. It is entered after the receiver self-surveyed its static reference position, or by user input. The over-determined clock solution is checked against TRAIM algorithm to remove faulty satellites from the solution. In this mode the receiver will no longer update its position or velocity, only solving for receiver clock bias and bias rate to maintain the 1PPS output.

The PVT mode is for navigation type of application, less used with timing application. In this mode, TRAIM and single-satellite 1PPS generation is not supported.

1PPS Quantization Error

Venus838LPx-T uses 81.838335MHz clock for 1PPS generation, which has period of 12nsec. By steering 1PPS output rising edge closest to UTC second, there remains a quantization error of half clock period, +/-6nsec. The amount of quantization error is reported by the Venus838LPx-T using SkyTraQ proprietary NMEA message \$PSTI,00; this information can be used to reduce the effective amount of jitter on 1PPS output.

The figures below illustrate the characteristic of the 1PPS signal.

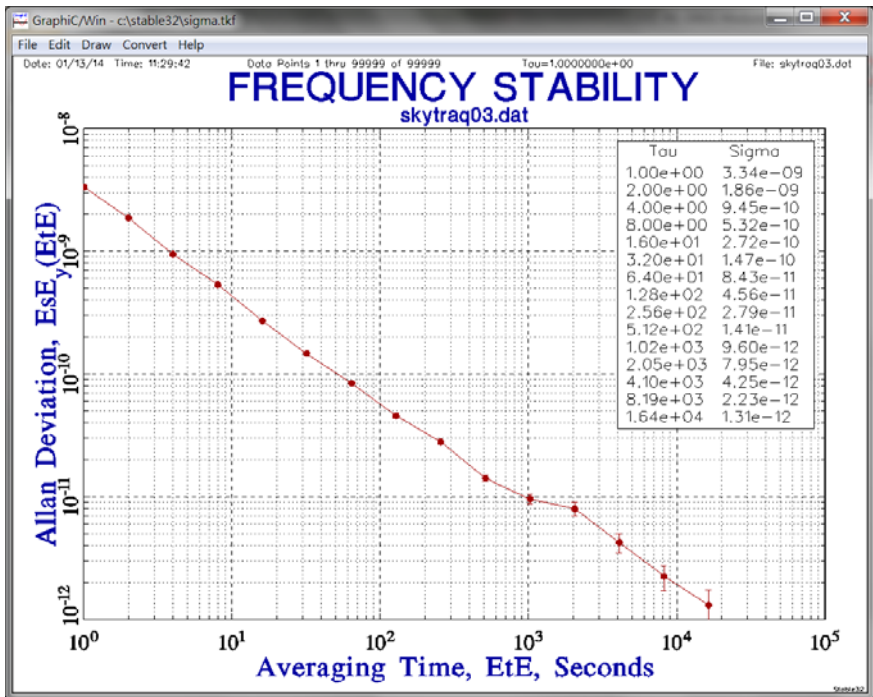
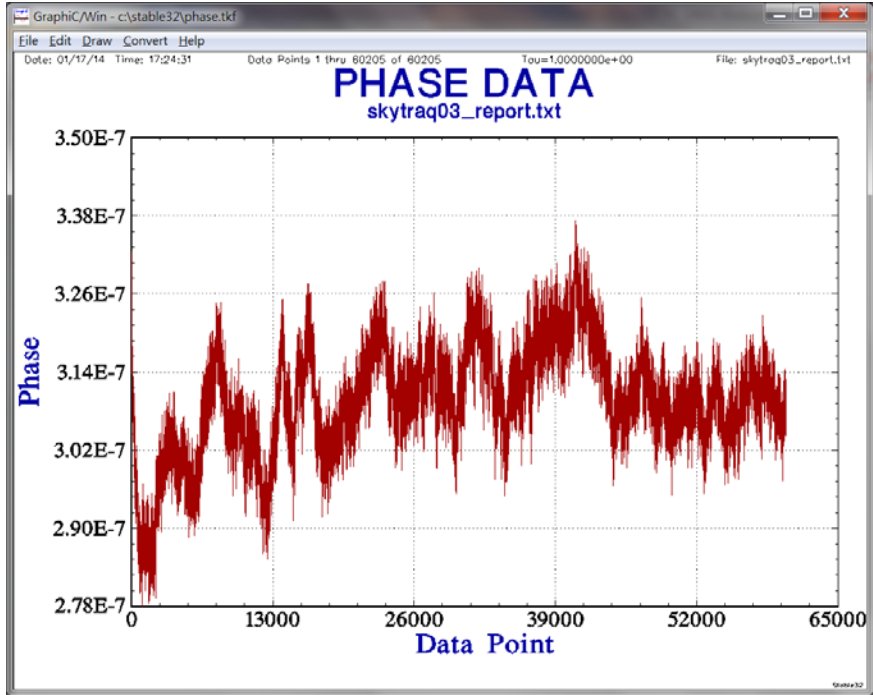

VENUS838LPx-T PIN-OUT DIAGRAM

Venus838LPx-T-L / Venus838LPx-T-D Top View

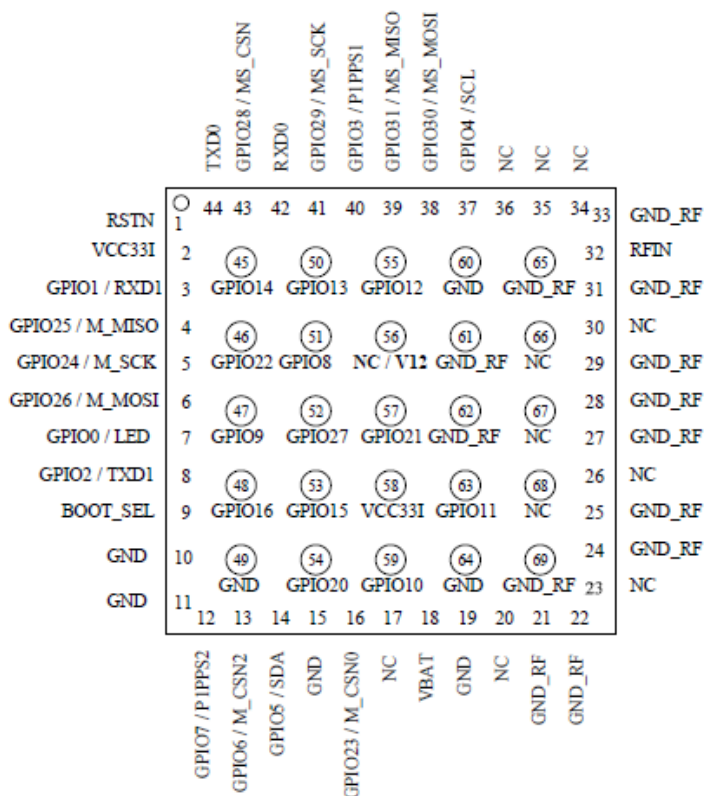

Figure-2 Venus838LPx-T Pin-Out Diagram

VENUS838LPx-T PIN DEFINITION

Pin Number	Signal Name	Type	Description
1	RSTN	Input	Active LOW reset input, 3.3V LVTTTL
2	VCC33I	Power Input	Main voltage supply input, 2.8V ~ 3.6V
3	GPIO1 / RXD1	Bidir	General purpose I/O pin, 3.3V LVTTTL Or receive input of the asynchronous UART port Default not used
4	GPIO25 / M_MISO	Bidir	General purpose I/O pin, 3.3V LVTTTL Or SPI master input Default not used
5	GPIO24 / M_SCK	Bidir	General purpose I/O pin, 3.3V LVTTTL Or SPI master clock Default not used
6	GPIO26 / M_MOSI	Bidir	General purpose I/O pin, 3.3V LVTTTL Or SPI master output Default not used
7	LED / GPIO0	Bidir	Navigation status indicator (default) Or General purpose I/O. 3.3V LVTTTL
8	GPIO2 / TXD1	Bidir	General purpose I/O pin. 3.3V LVTTTL Or transmit output of the asynchronous UART port Default not used
9	BOOT_SEL	Bidir	Boot mode selection. Pull-high or pull-low 1: execute from internal Flash 0: execute from internal ROM This is opposite of Venus638LPx-T
10	GND	Power	System ground
11	GND	Power	System ground
12	GPIO7 / P1PPS2	Bidir	General purpose I/O pin, 3.3V LVTTTL

			Second P1PPS output, can be set to 1PPS phase-locked 10MHz Default unused
13	GPIO6 / M_CSN2	Bidir	General purpose I/O pin, 3.3V LVTTL Or SPI master chip select #2 Default not used
14	GPIO5 / SDA	Bidir	General purpose I/O pin, 3.3V LVTTL Or I2C serial data Default not used
15	GND	Power	System ground
16	GPIO23 / M_CSN0	Bidir	General purpose I/O pin, 3.3V LVTTL Or SPI master chip select #0 Default not used
17	NC		Not connected, empty pin
18	VBAT	Power Input	Supply voltage for internal RTC and backup SRAM, 2.5V ~ 3.6V. VBAT should be powered by non-volatile supply voltage to have optimal performance. Maximum VBAT current draw when VCC33I is removed is 35uA. If VBAT is connected to VCC33I, powered off as VCC33I power is removed, then it'll cold start every time. For applications that do not care lesser performance cold starting every time, this pin can be connected to VCC33I. Must not be left unconnected. When there is leap second change during operation, the new leap second information will be written to internal Flash at next power on; if VBAT is not maintained when VCC33I is removed, default leap second cannot be updated and there can be initial second difference at power on before the new leap second is decoded from signal.
19	GND	Power	System ground
20	NC		Not connected, empty pin
21	GND_RF	Power	RF section system ground
22	GND_RF	Power	RF section system ground
23	NC		Not connected, empty pin
24	GND_RF	Power	RF section system ground
25	GND_RF	Power	RF section system ground
26	NC		Not connected, empty pin
27	GND_RF	Power	RF section system ground
28	GND_RF	Power	RF section system ground
29	GND_RF	Power	RF section system ground
30	NC		Not connected, empty pin
31	GND_RF	Power	RF section system ground
32	RFIN	Input	GPS signal input, connect to GPS antenna.
33	GND_RF	Power	RF section system ground
34	NC		Not connected, empty pin
35	NC		Not connected, empty pin
36	NC		Not connected, empty pin
37	GPIO4 / SCL	Bidir	General purpose I/O pin, 3.3V LVTTL Or I2C SCL clock Default not used
38	GPIO30 / MS_MOSI	Bidir	General purpose I/O pin, 3.3V LVTTL Or SPI master/slave data output Default not used
39	GPIO31 / MS_MISO	Bidir	General purpose I/O pin, 3.3V LVTTL Or SPI master/slave data input Default not used
40	P1PPS / GPIO3	bidir	1 pulse per second output. Active after position fix; goes HIGH for about 800usec, 3.3V LVTTL (default) Or general purpose I/O pin
41	GPIO29 / MS_SCK	Output	General purpose output pin, 3.3V LVTTL Or SPI master/slave clock Default not used
42	RXD0	Input	Received input of the asynchronous UART port. Used to input binary command to the GPS receiver. 3.3V LVTTL
43	GPIO28 / MS_CSN	Bidir	General purpose I/O pin, 3.3V LVTTL Or SPI master/slave chip select Default not used

44	TXD0	Output	Transmit output of the asynchronous UART port. Used to output standard NMEA-0183 sentence or response to input binary command. 3.3V LVTTTL
45	GPIO14	Bidir	General purpose I/O pin, 3.3V LVTTTL Default not used
46	GPIO22 / M_CSN1	Bidir	General purpose I/O pin, 3.3V LVTTTL Or SPI master chip select #1 Default not used
47	GPIO9	Bidir	General purpose I/O pin, 3.3V LVTTTL Default not used
48	GPIO16	Bidir	General purpose I/O pin, 3.3V LVTTTL Default not used
49	GND		System ground
50	GPIO13	Bidir	General purpose I/O pin, 3.3V LVTTTL Default not used
51	GPIO8	Bidir	General purpose I/O pin, 3.3V LVTTTL Default not used
52	GPIO27	Input	General purpose I/O pin, 3.3V LVTTTL Default not used
53	GPIO15	Bidir	General purpose I/O pin, 3.3V LVTTTL Default not used
54	GPIO20 / PWM0	Bidir	General purpose I/O pin, 3.3V LVTTTL Or PWM output #0 Default not used
55	GPIO12	Bidir	General purpose I/O pin, 3.3V LVTTTL Default not used
56	NC / V12		NC pin for Venus838FLPx-L 1.2V supply input pin for Venus838FLPx-D
57	GPIO21 / PWM1	Output	General purpose I/O pin, 3.3V LVTTTL Or PWM output #1 Default not used
58	VCC33I	Power Input	Main voltage supply input, 2.8V ~ 3.6V
59	GPIO10	Bidir	General purpose I/O pin, 3.3V LVTTTL Default not used
60	GND	Power	System ground
61	GND_RF	Power	RF section system ground
62	GND_RF	Power	RF section system ground
63	GPIO11	Bidir	General purpose I/O pin, 3.3V LVTTTL Default not used
64	GND	Power	System ground
65	GND_RF	Power	RF section system ground
66,67,68	NC		Not connected, empty pin
69	GND_RF	Power	RF section system ground

When using Venus838LPx-T-L to replace Venus634LPx-T, pin-45 ~ pin-69 can all be left unconnected.
When using Venus838LPx-T-D, 1.2V need to be supplied at pin-56
The NC pins are to be left unconnected.

DC CHARACTERISTICS OF DIGITAL INTERFACE

Below is when VCC3I is at nominally 3.3V

Parameter	Min.	Typ.	Max.	Units
Input Low Voltage			0.8	Volt
Input High Voltage	2.0			Volt
Output Low Voltage, I _{ol} = 4 ~ 7.8mA			0.4	Volt
Output High Voltage, I _{oh} = 4.6 ~ 15.4mA	2.4			Volt

MECHANICAL DIMENSION

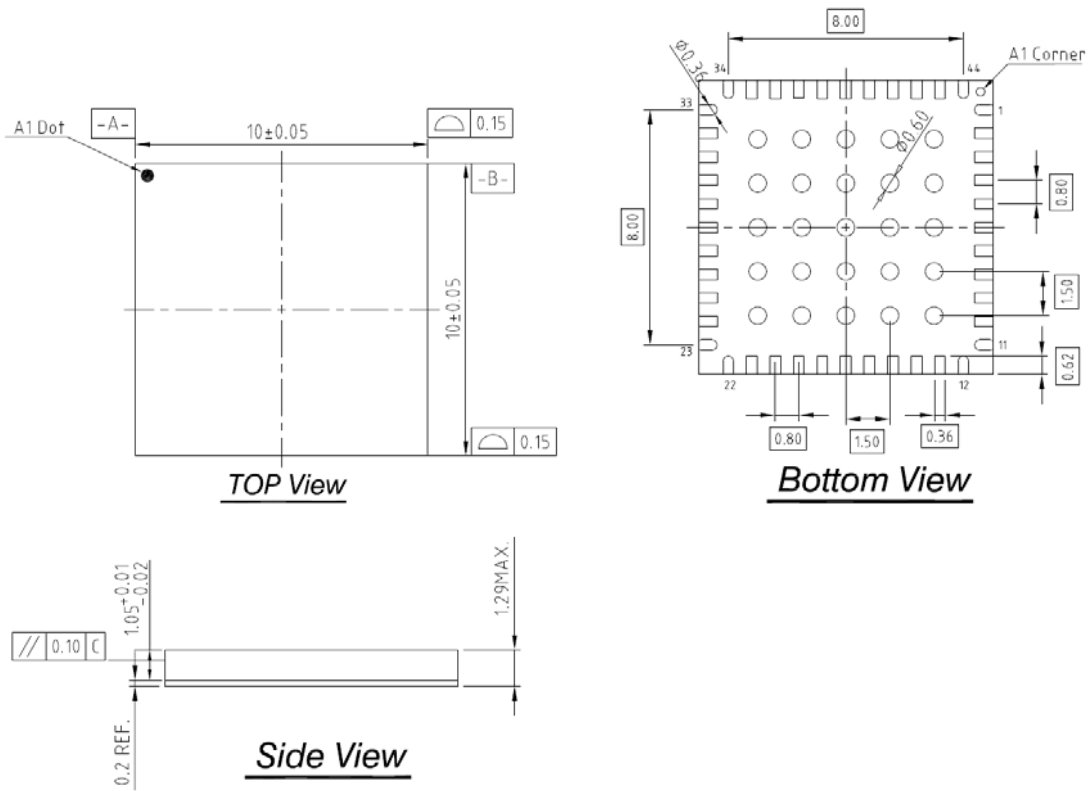

RECOMMENDED PCB FOOTPRINT

Package size = 10 mm x 10mm x 1.3 mm
 Package Pad = 15 x 21 mil
 Package Pitch= 0.8 mm

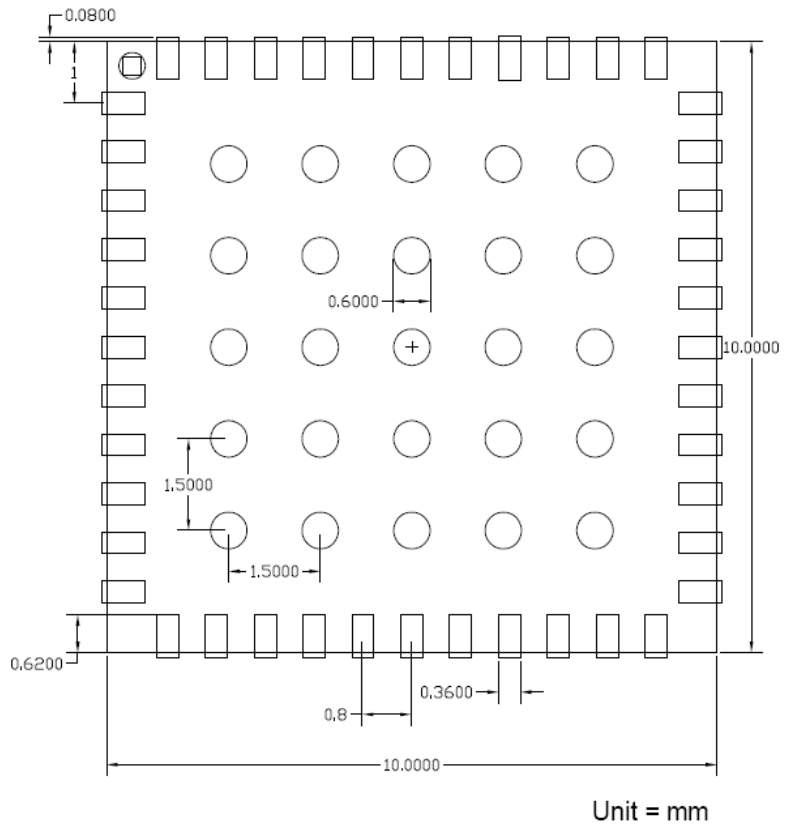
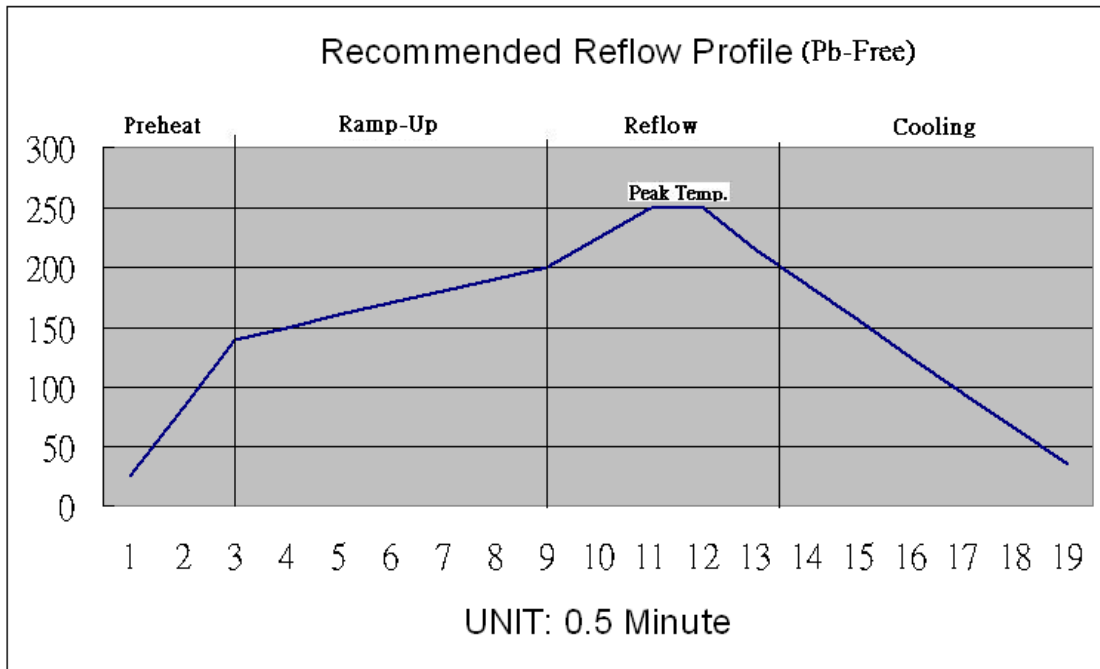

Figure-3 Recommended PCB Footprint.

RECOMMENDED REFLOW PROFILE



Temperature (°C)	25	82.5	140	150	160	170	180	190	200	225	250	250	215	185	155	125	95	65	35
Time(minute)	0	0.5	1	1.5	2	2.5	3	3.5	4	4.5	5	5.5	6	6.5	7	7.5	8	8.5	9

Profile Description	SnPb Eutectic Process	Lead Free Process
Preheat		
Maximum Temperature	100+/-10 °C	140+/-10 °C
Time(Δ T)	40~60s	50~70s
Ramp-Up		
Ramp-Up Rate	1 °C/s Max.	1 °C/s Max.
Time(Δ T)	120~150s	160~200s
Reflow		
Maximum Temperature	Peak Temp.	Peak Temp.
Minimum Temperature	180+/-5°C	200+/-10°C
Peak Temperature	220+/-2°C	250+/-2°C
Time(Δ T) during Peak Temp. +/-2°C	10~30s	20~40s
Reflow Time(Δ T)	120~150s	120~150s
Cooling		
Cooling Rate	1.5 °C/s Max	1.5 °C/s Max
Time(Δ T)	60~120s	150~180s

VENUS838LPx-T-L APPLICATION CIRCUIT

- 1. RF_IN trace have 50 ohm impedance
- 2. L1 Optional biasing for active antenna

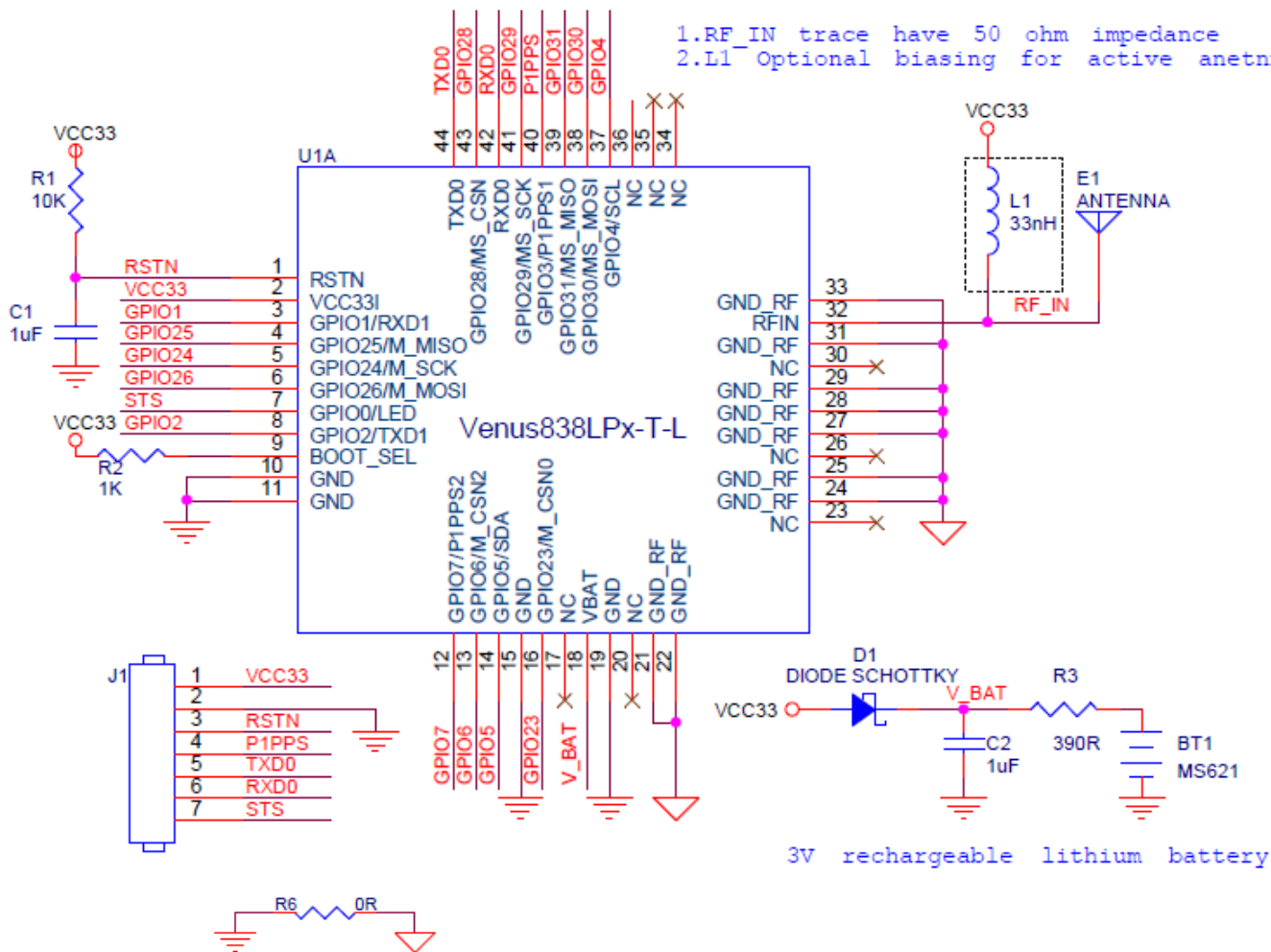

3V rechargeable lithium battery

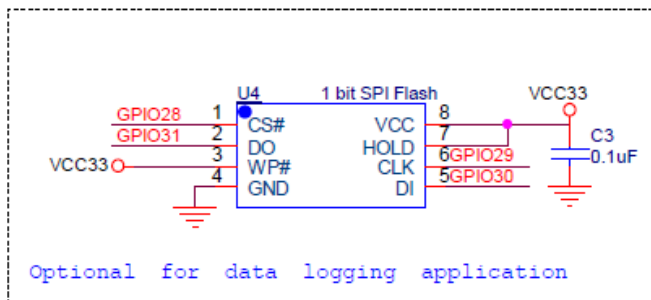
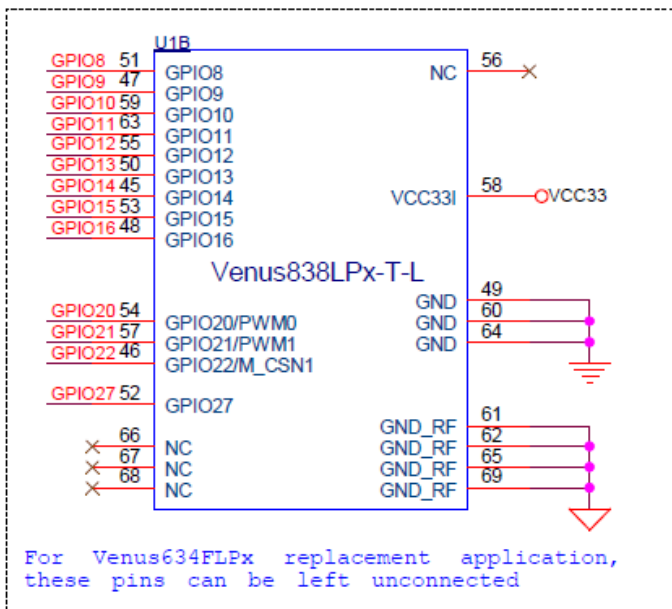

Optional for data logging application

VENUS838LPx-T-D APPLICATION CIRCUIT

- 1. RF_IN trace have 50 ohm impedance
- 2. L1 Optional biasing for active antenna

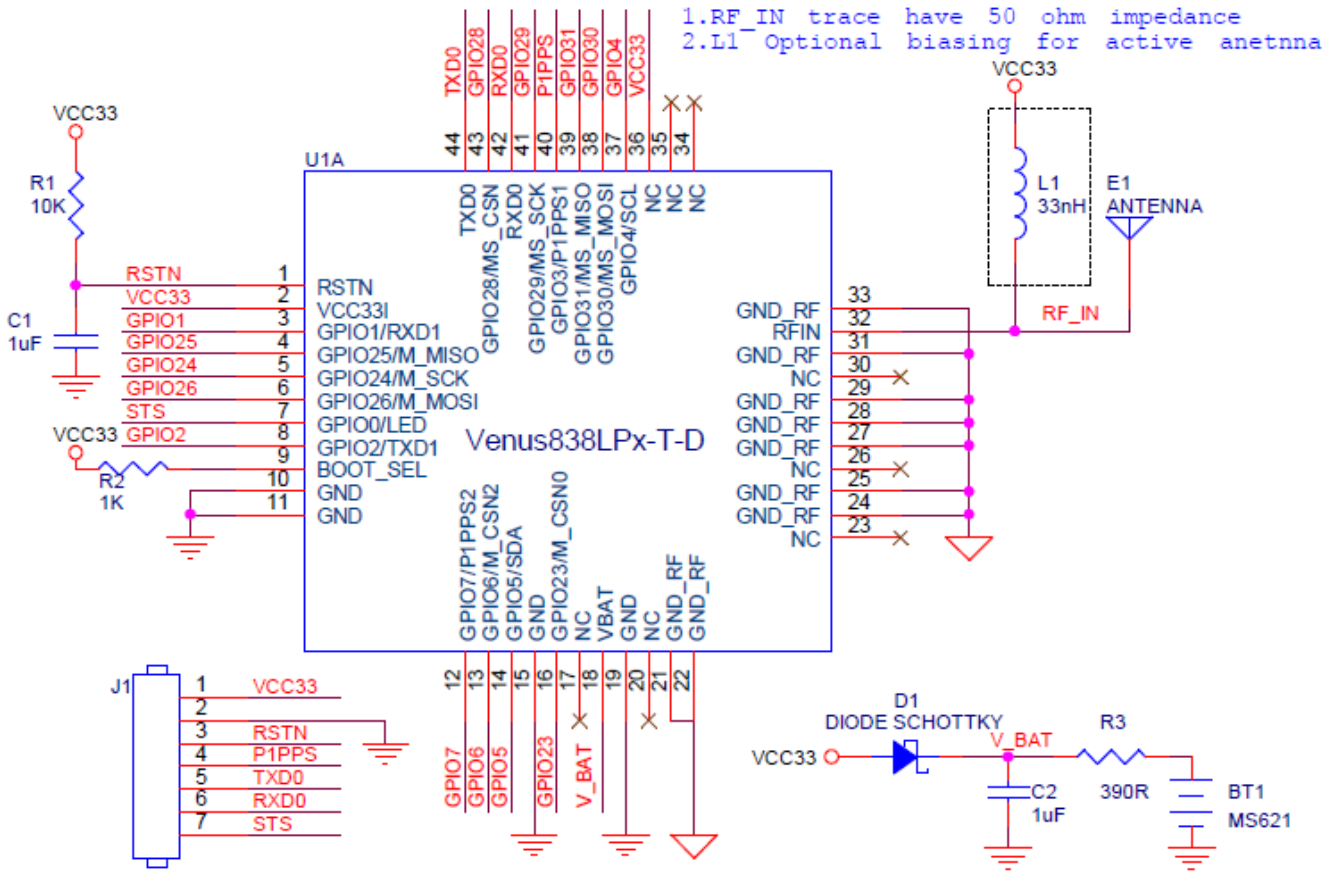

3V rechargeable lithium battery

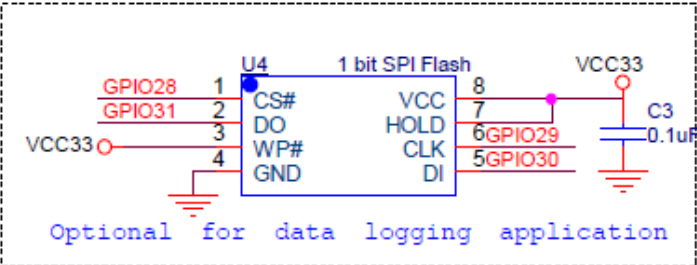

U3 XCA201A06BCR
 $V_{out} = 0.6 * (1 + R4/R5) = 1.2V$

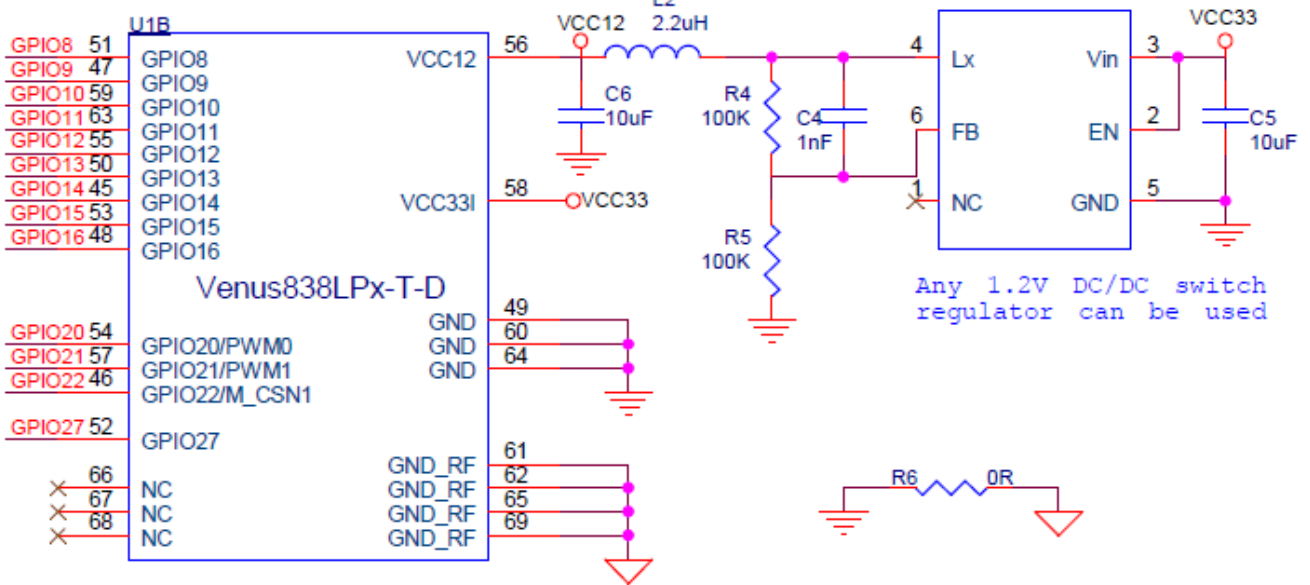

Any 1.2V DC/DC switch regulator can be used

APPLICATION CIRCUIT INTERFACE SIGNALS

STS:	Signal to indicate GPS position status, 3.3V LVTTTL. Active low for no-fix, toggle every second after position fix.
P1PPS:	1 pulse per second time-mark (3.3V LVTTTL)
RSTN:	Active low reset input
VCC33:	3.3V power input
RXD0:	UART input (3.3V LVTTTL)
TXD0:	UART output (3.3V LVTTTL)

APPLICATION INFORMATION

1. For fast-rising power supply, a simple series R/C reset delay to pin-1, RSTN, as indicated in the application circuit is suitable. For system having slow-rising power supply, a reset IC providing 2~5ms reset duration may be necessary.
2. The RF input of Venus838LPx-T is already matched to 50-ohm. Passive antenna matched to 50-ohm can be directly applied.
3. For using Venus838LPx-T with active antenna, one with gain in range of 10~30dB and noise figure < 2dB can be used. Power to the active antenna needs to be applied externally.
4. Pin-18 VBAT supplies backup power to the real-time clock and backup SRAM for fast startup. For portable applications where there is battery with voltage in range of 2.5V ~ 3.6V as the main source, the VBAT pin can be directly connected to it. If VBAT is connected to main power as pin-2, no supply voltage as Venus838LPx-T is powered off, then it'll cold start every time and GPS performance will not be optimal.
5. Like BGA device, the Venus838LPx-T is moisture sensitive. It needs to be handled with care to void damage from moisture absorption and SMT re-flow. The device should be baked for 24 hours at 125-degC before mounting for SMT re-flow if it has been removed from the protective seal for more than 48^{*1}hours.
6. If hot plug/remove power and UART serial interface, add at least 1K-ohm series resistor to pin-42 RXD0 and pin-44 TXD0 to improve ESD protection.

*1: Actual will be longer, moisture sensitivity level still undergoing verification.

SLEEP MODE

For application requiring sleep mode, it can be implemented using regulator with enable control as below figure shows. To put Venus838LPx-T to sleep, the power to Venus838LPx-T is cut off by disabling the regulator via host processor GPIO pin. In sleep mode, VBAT consume less than 10uA. Fast start up operation is provided by keeping supply voltage to VBAT constant, retaining the internal data and keep RTC running while Venus838LPx-T is put to sleep or when supply 3.3V power is removed.

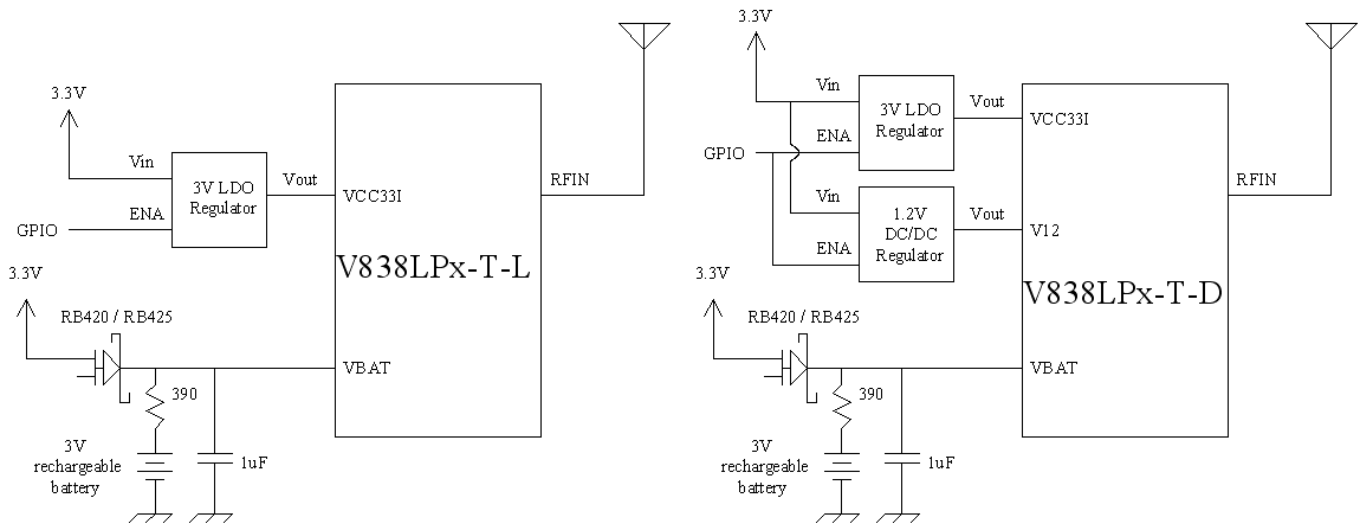

For applications needing sleep mode but cannot have extra cost of adding a rechargeable backup supply battery, it can be implemented as below figure shows. It will provide fast start up when Venus838LPx-T is put to sleep and awakened, but will cold start every time when the 3.3V supply voltage is removed and re-applied again.

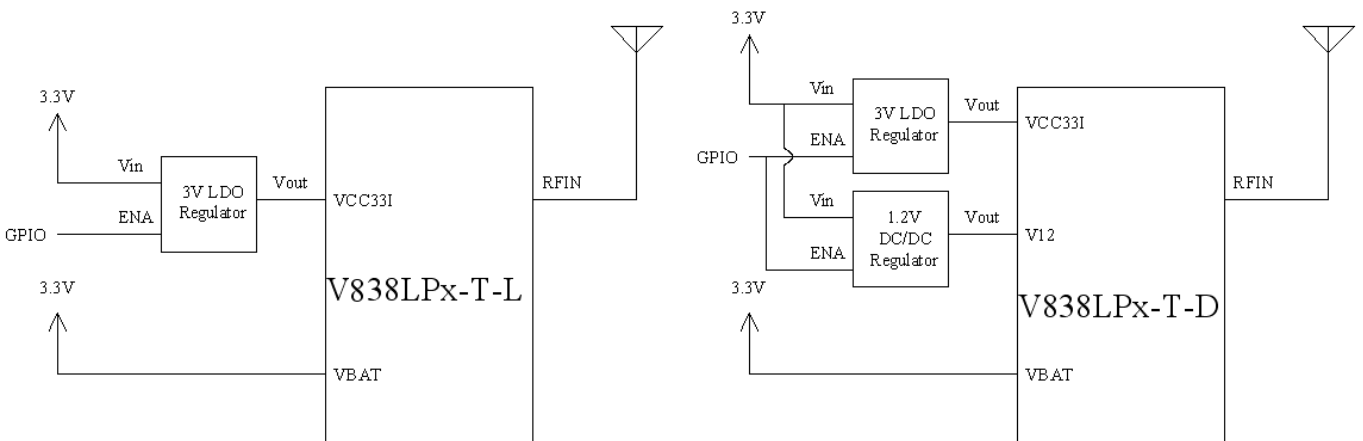

When using sleep mode, add 10K ~ 20K series resistor on pin-42 RXD0 to reduce leakage current.

PACKAGE

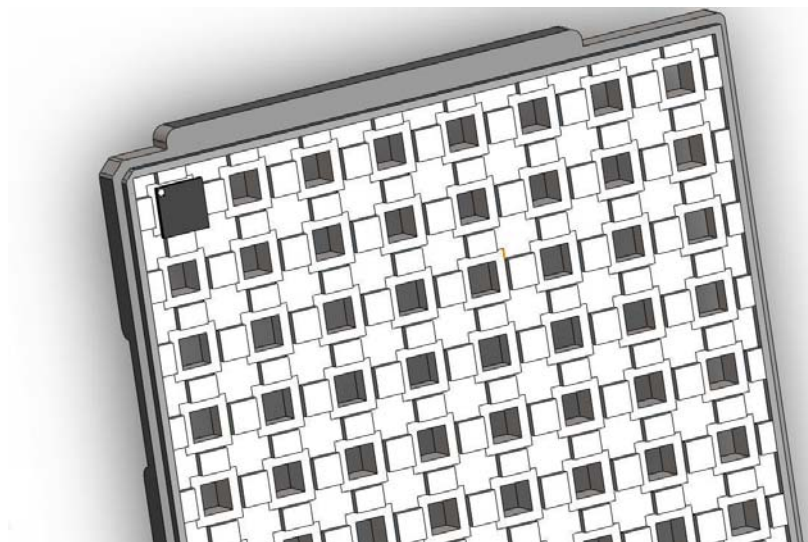
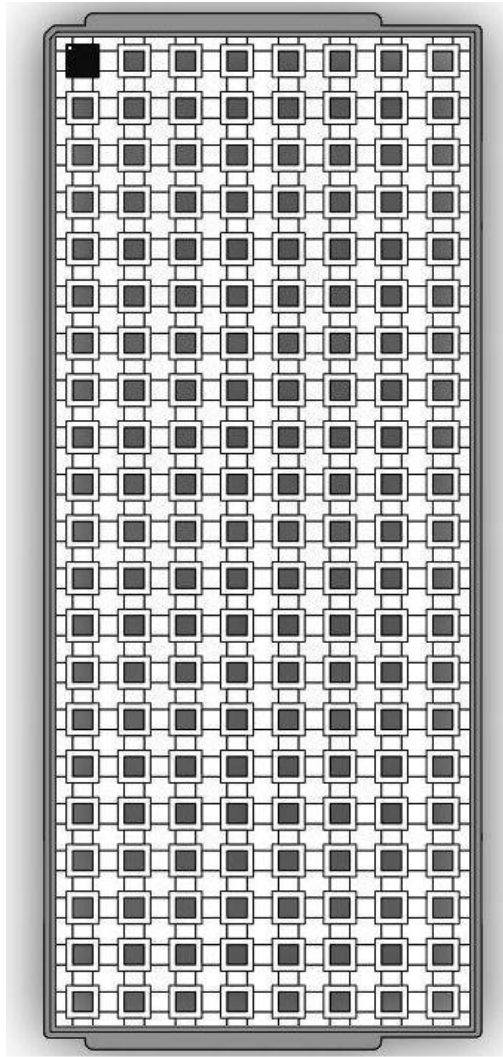

NMEA MESSAGES

The full descriptions of supported NMEA messages are provided at the following paragraphs.

GGA - Global Positioning System Fix Data

Time, position and fix related data for a GPS receiver.

Structure:

```
$GPGGA,hhmmss.sss,ddmm.mmmm,a,dddmm.mmmm,a,x,xx,x.x,x.x,M,,,,,xxxx*hh<CR><LF>
```

1 2 3 4 5 6 7 8 9 10 11

Example:

```
$GPGGA,111636.932,2447.0949,N,12100.5223,E,1,11,0.8,118.2,M,,,,,0000*02<CR><LF>
```

Field	Name	Example	Description
1	UTC Time	111636.932	UTC of position in hhmmss.sss format, (000000.000 ~ 235959.999)
2	Latitude	2447.0949	Latitude in ddm.mmmm format Leading zeros transmitted
3	N/S Indicator	N	Latitude hemisphere indicator, 'N' = North, 'S' = South
4	Longitude	12100.5223	Longitude in dddmm.mmmm format Leading zeros transmitted
5	E/W Indicator	E	Longitude hemisphere indicator, 'E' = East, 'W' = West
6	GPS quality indicator	1	GPS quality indicator 0: position fix unavailable 1: valid position fix, SPS mode 2: valid position fix, differential GPS mode 3: GPS PPS Mode, fix valid 4: Real Time Kinematic. System used in RTK mode with fixed integers 5: Float RTK. Satellite system used in RTK mode. Floating integers 6: Estimated (dead reckoning) Mode 7: Manual Input Mode 8: Simulator Mode
7	Satellites Used	11	Number of satellites in use, (00 ~ 20)
8	HDOP	0.8	Horizontal dilution of precision, (0.0 ~ 99.9)
9	Altitude	108.2	mean sea level (geoid), (-9999.9 ~ 17999.9)
10	DGPS Station ID	0000	Differential reference station ID, 0000 ~ 1023 NULL when DGPS not used
11	Checksum	02	

GLL – Latitude/Longitude

Latitude and longitude of current position, time, and status.

Structure:

\$GPGLL,ddmm.mmmm,a,dddmm.mmmm,a,hhmmss.sss,A,a*hh<CR><LF>

1 2 3 4 5 6 7 8

Example:

\$GPGLL,2447.0944,N,12100.5213,E,112609.932,A,A*57<CR><LF>

Field	Name	Example	Description
1	Latitude	2447.0944	Latitude in ddmm.mmmm format Leading zeros transmitted
2	N/S Indicator	N	Latitude hemisphere indicator 'N' = North 'S' = South
3	Longitude	12100.5213	Longitude in dddmm.mmmm format Leading zeros transmitted
4	E/W Indicator	E	Longitude hemisphere indicator 'E' = East 'W' = West
5	UTC Time	112609.932	UTC time in hhmmss.sss format (000000.000 ~ 235959.999)
6	Status	A	Status, 'A' = Data valid, 'V' = Data not valid
7	Mode Indicator	A	Mode indicator 'N' = Data not valid 'A' = Autonomous mode 'D' = Differential mode 'E' = Estimated (dead reckoning) mode 'M' = Manual input mode 'S' = Simulator mode
8	Checksum	57	

GSA – GNSS DOP and Active Satellites

GPS receiver operating mode, satellites used in the navigation solution reported by the GGA or GNS sentence and DOP values.

Structure:

```
$GPGSA,A,x,xx,xx,xx,xx,xx,xx,xx,xx,xx,xx,xx,xx,x.x,x.x,x.x*x*hh<CR><LF>
    1 2 3 3 3 3 3 3 3 3 3 3 3 4 5 6 7
```

Example:

```
$GPGSA,A,3,05,12,21,22,30,09,18,06,14,01,31,,1.2,0.8,0.9*36<CR><LF>
```

Field	Name	Example	Description
1	Mode	A	Mode 'M' = Manual, forced to operate in 2D or 3D mode 'A' = Automatic, allowed to automatically switch 2D/3D
2	Mode	3	Fix type 1 = Fix not available 2 = 2D 3 = 3D
3	Satellite used 1 ~ 12	05,12,21,22,3 0,09,18,06,14, 01,31,,	Satellite ID number, 01 to 32, of satellite used in solution, up to 12 transmitted
4	PDOP	1.2	Position dilution of precision (0.0 to 99.9)
5	HDOP	0.8	Horizontal dilution of precision (0.0 to 99.9)
6	VDOP	0.9	Vertical dilution of precision (0.0 to 99.9)
7	Checksum	36	

GSV – GNSS Satellites in View

Number of satellites (SV) in view, satellite ID numbers, elevation, azimuth, and SNR value. Four satellites maximum per transmission.

Structure:

```
$GPGSV,x,x,xx,xx,xx,xxx,xx,...,xx,xx,xxx,xx *hh<CR><LF>
  1 2 3 4 5 6 7 4 5 6 7 8
```

Example:

```
$GPGSV,3,1,12,05,54,069,45,12,44,061,44,21,07,184,46,22,78,289,47*72<CR><LF>
$GPGSV,3,2,12,30,65,118,45,09,12,047,37,18,62,157,47,06,08,144,45*7C<CR><LF>
$GPGSV,3,3,12,14,39,330,42,01,06,299,38,31,30,256,44,32,36,320,47*7B<CR><LF>
```

Field	Name	Example	Description
1	Number of message	3	Total number of GSV messages to be transmitted (1-5)
2	Sequence number	1	Sequence number of current GSV message
3	Satellites in view	12	Total number of satellites in view (00 ~ 20)
4	Satellite ID	05	Satellite ID number, GPS: 01 ~ 32, SBAS: 33 ~ 64 (33 = PRN120)
5	Elevation	54	Satellite elevation in degrees, (00 ~ 90)
6	Azimuth	069	Satellite azimuth angle in degrees, (000 ~ 359)
7	SNR	45	C/No in dB (00 ~ 99) Null when not tracking
8	Checksum	72	

RMC – Recommended Minimum Specific GNSS Data

Time, date, position, course and speed data provided by a GNSS navigation receiver.

Structure:

\$GPRMC,hhmmss.sss,A,dddmm.mmmm,a,dddmm.mmmm,a,x.x,x.x,ddmmy,,a*hh<CR><LF>
 1 2 3 4 5 6 7 8 9 10 11

Example:

\$GPRMC,111636.932,A,2447.0949,N,12100.5223,E,000.0,000.0,030407,,A*61<CR><LF>

Field	Name	Example	Description
1	UTC time	0111636.932	UTC time in hhmmss.sss format (000000.00 ~ 235959.999)
2	Status	A	Status 'V' = Navigation receiver warning 'A' = Data Valid
3	Latitude	2447.0949	Latitude in dddmm.mmmm format Leading zeros transmitted
4	N/S indicator	N	Latitude hemisphere indicator 'N' = North 'S' = South
5	Longitude	12100.5223	Longitude in dddmm.mmmm format Leading zeros transmitted
6	E/W Indicator	E	Longitude hemisphere indicator 'E' = East 'W' = West
7	Speed over ground	000.0	Speed over ground in knots (000.0 ~ 999.9)
8	Course over ground	000.0	Course over ground in degrees (000.0 ~ 359.9)
9	UTC Date	030407	UTC date of position fix, ddmmyy format
10	Mode indicator	A	Mode indicator 'N' = Data not valid 'A' = Autonomous mode 'D' = Differential mode 'E' = Estimated (dead reckoning) mode 'M' = Manual input mode 'S' = Simulator mode
11	checksum	61	

VTG – Course Over Ground and Ground Speed

The Actual course and speed relative to the ground.

Structure:

```
GPVTG,x.x,T,,M,x.x,N,x.x,K,a*hh<CR><LF>
    1    2    3    4 5
```

Example:

```
$GPVTG, 000.0,T,,M,000.0,N,0000.0,K,A*3D<CR><LF>
```

Field	Name	Example	Description
1	Course	000.0	True course over ground in degrees (000.0 ~ 359.9)
2	Speed	000.0	Speed over ground in knots (000.0 ~ 999.9)
3	Speed	0000.0	Speed over ground in kilometers per hour (0000.0 ~ 1800.0)
4	Mode	A	Mode indicator 'N' = not valid 'A' = Autonomous mode 'D' = Differential mode 'E' = Estimated (dead reckoning) mode 'M' = Manual input mode 'S' = Simulator mode
5	Checksum	3D	

ZDA – Time & Date

UTC, day, month, year and local time zone.

Structure:

\$GPZDA,hhmmss.sss,xx,xx,xxxx,xx,xx*hh<CR><LF>

1 2 3 4 5 6 7

Example:

\$GPZDA,052633.376,13,07,2012,00,00*51<CR><LF>

Field	Name	Example	Description
1	UTC time	0111636.932	UTC time in hhmmss.sss format (000000.000 ~ 235959.999)
2	Day	13	Day, 01 to 31
3	Month	07	Month, 01 to 12
4	Year	2012	Year in yyyy format
5	Local zone hours	00	Local zone hours, 00 to +/- 13 hrs
6	Local zone minutes	00	Local zone minutes, 00 to +59
7	checksum	51	

STI,00 – 1 PPS timing report

An output message, id 0x0, contains information of 1 PPS timing mode, 1 PPS survey length and 1PPS quantization error.

Structure:

\$PSTI,00,x,xx,xx,x,x *hh<CR><LF>

1 2 3 4 5 6 7

Example:

\$PSTI,00,1,1985,-12.4,30,5*28<CR><LF>

Field	Name	Example	Description
1	00	00	Proprietary NMEA message identifier
2	1PPS Timing Mode	1	0 = PVT Mode 1 = Survey Mode 2 = Static Mode
3	1PPS Survey Length	1985	Survey length for Survey Mode values 60 ~ 1209600
4	1PPS Quantization Error	-12.4	Quantization error of 1PPS timing values -31 ~ +31
5	Position Standard Deviation Threshold	30	Position standard deviation threshold for comparing self-surveyed position result. At end of self-survey period, if position standard deviation from averaged center point is less than this threshold, static mode is entered; otherwise survey mode is restarted again. Default threshold is 30m. Output null field when not in survey mode.
6	Calculated Position Standard Deviation After Self-Survey	5	When still in survey mode, this field output 0. At end of self-survey period, if position standard deviation from averaged center point is less than the Position Standard Deviation Threshold, static mode is entered; otherwise survey mode is restarted and computed position standard deviation value is output. Null field when not in survey mode.
7	Checksum	28	

ORDERING INFORMATION

Part Number	Description
Venus838LPx-T-L	Timing mode GPS receiver module (internal 1.2V LDO version)
Venus838LPx-T-D	Timing mode GPS receiver module (external 1.2V version)

SkyTraq Technology, Inc.
4F, No.26, Minsiang Street, Hsinchu, Taiwan, 300
Phone: +886 3 5678650
Fax: +886 3 5678680
Email: info@skytraq.com.tw

© 2014 SkyTraq Technology Inc. All rights reserved.

Not to be reproduced in whole or part for any purpose without written permission of SkyTraq Technology Inc ("SkyTraq"). Information provided by SkyTraq is believed to be accurate and reliable. These materials are provided by SkyTraq as a service to its customers and may be used for informational purposes only. SkyTraq assumes no responsibility for errors or omissions in these materials, nor for its use. SkyTraq reserves the right to change specification at any time without notice.

These materials are provided "as is" without warranty of any kind, either expressed or implied, relating to sale and/or use of SkyTraq products including liability or warranties relating to fitness for a particular purpose, consequential or incidental damages, merchantability, or infringement of any patent, copyright or other intellectual property right. SkyTraq further does not warrant the accuracy or completeness of the information, text, graphics or other items contained within these materials. SkyTraq shall not be liable for any special, indirect, incidental, or consequential damages, including without limitation, lost revenues or lost profits, which may result from the use of these materials.

SkyTraq products are not intended for use in medical, life-support devices, or applications involving potential risk of death, personal injury, or severe property damage in case of failure of the product.

Change Log

Version 0.6, July 24, 2017

1. Added effect of VBAT not kept non-volatile on leap second change in pin description section.

Version 0.5, October 5, 2016

2. Updated GGA and GSV message fields related to number of satellites.

Version 0.4, April 12, 2015

1. Updates P1PPS pulse width

Version 0.3, November 18, 2014

1. Added description for filed #5 and #6 in PSTI,00 message

Version 0.2, March 7, 2014

1. Pin-36 changed to NC

Version 0.1, February 24, 2014

1. Initial release