

PX1105R



Small-Size Dual-Band GNSS Receiver for Centimeter-Level Accuracy Applications

Features

- Centimeter-level accuracy RTK receiver
- GPS/QZSS L1/L5, Galileo E1/E5a, BDS B1I/B2a, GLONASS L1, NavIC L5
- 10.1mm x 9.7mm size
- NMEA-0183 and RTCM 3.x protocol
- Easy to integrate
- Operating temperature -40 ~ +85°C
- RoHS compliant

Applications

- Machine control & automation
- Unmanned aerial vehicle
- Precision agriculture
- GIS data collection
- Precision heading & attitude

The PX1105R offers centimeter-level accuracy based on carrier phase RTK technique and can be used for a wide range of high-accuracy positioning applications. Its 10.1mm x 9.7mm form factor makes it ideal for mobile precision positioning application requiring small size.

The receiver receives RTCM 3.x data from a local base station, a virtual reference station (VRS) in a Network RTK configuration, or another SkyTraQ RTK receiver setup as in base station mode to perform carrier phase RTK processing, achieving centimeter level accurate relative positioning.

The PX1105R receiver is based on SkyTraQ's high-performance Phoenix GNSS chipset, featuring fast signal acquisition search engine and high-sensitivity track engine. Search engine performs 16 million time-frequency hypothesis testing per second, offering industry-leading signal acquisition performance.

The receiver is optimized for mass market applications requiring high-precision centimeter-level accuracy, high-performance, low power, and lower cost.

PX1105R use GNSS chips qualified according to AEC-Q100 and are manufactured in ISO/TS 16949 certified sites.

TECHNICAL SPECIFICATIONS

| | | | |
|-----------------------|---|---------------------------|-----------------|
| Receiver Type | 230 channel Phoenix GNSS engine GPS/QZSS L1/L5, Galileo E1/E5a, BDS B1I/B2a, GLONASS L1, NavIC L5 | | |
| Accuracy | Position | 1.5m CEP | autonomous mode |
| | | 1cm + 1ppm | RTK mode |
| | Velocity | 0.05m/sec* ¹ | |
| | Time | 12ns | |
| | Moving Base Heading | 0.13 degree* ² | |
| Time to First Fix | 1 second hot-start under open sky (average) 28 second warm-start under open sky (average) 29 second cold-start under open sky (average) | | |
| RTK Convergence | < 10sec | | |
| Reacquisition | 1s | | |
| Max Update Rate | RTK 1 / 2 / 4 / 5 / 8 / 10 Hz | | |
| | Raw Measurement 1 / 2 / 4 / 5 / 8 / 10 / 20 Hz | | |
| | Moving Base RTK and Advance Moving Base RTK 1 / 2 / 4 / 5 / 8 Hz | | |
| | RTK: for precise positioning. Moving-Base (MB) RTK for precise heading. Advanced Moving Base (AMB) RTK for precise positioning & heading. | | |
| Operational Limits | Altitude < 80,000m and velocity < 515m/s | | |
| Serial Interface | 3.3V LVTTTL level | | |
| Protocol | NMEA-0183 V4.1 GGA, GLL, GSA, GSV, RMC, VTG 115200 baud, 8, N, 1 | | |
| | RTCM 3.x or SkyTraq raw data binary 115200 baud, 8, N, 1 | | |
| Datum | Default WGS-84 and user definable in stand-alone mode Depends on base reference frame when in RTK mode | | |
| Input Voltage | 3.3V DC +/-10% | | |
| Current Consumption | 115mA acquisition, 95mA tracking | | |
| Dimension | 10.1mm L x 9.7mm W x 2.9mm H | | |
| Weight: | 1.7g | | |
| Operating Temperature | -40°C ~ +85°C | | |
| Storage Temperature | -55 °C ~ +100°C | | |
| Humidity | 5% ~ 95% non-condensing | | |

*¹ 50% @ 30 m/s for dynamic operation

*² (1-sigma) heading accuracy using 1 meter baseline

FUNCTIONAL DESCRIPTION

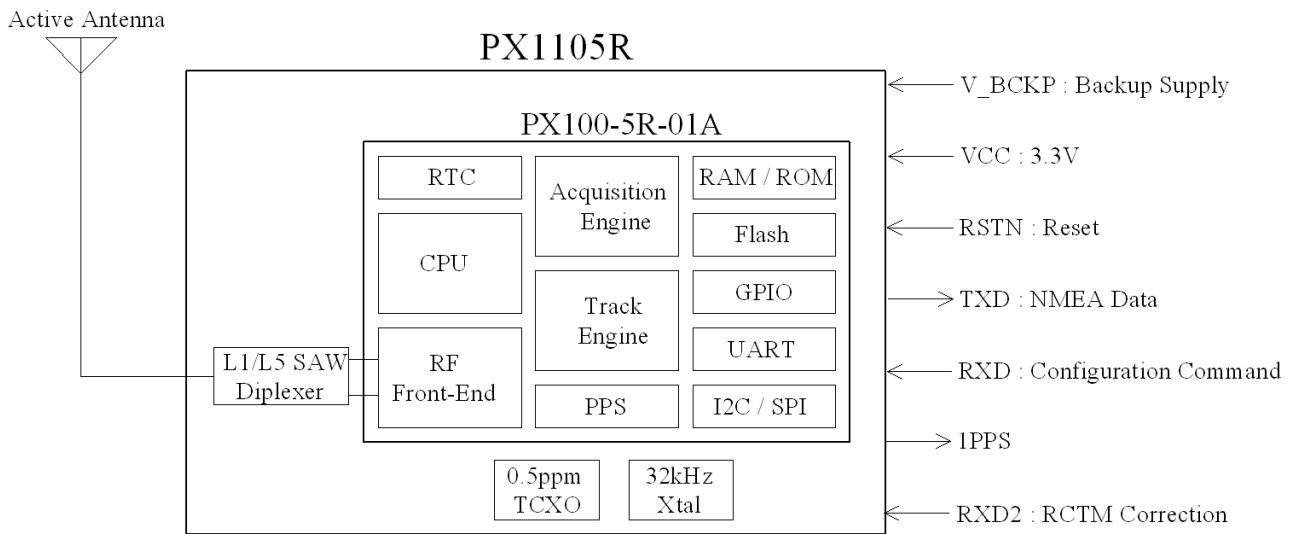

Active antenna is required to use with PX1105R. The received signal goes through a L1/L5 SAW diplexer to remove out-band interference, then to the PX100 GNSS receiver chip for RTK signal processing. Using correction data from an RTK base station, the rover PX1105R computes its position to centimeter-level accuracy relative to the base station.

SUPPORTED RTCM MESSAGES

When operating in rover mode, PX1105R can decode following RTCM 3.3 messages:

| RTCM Message Type | Description |
|-------------------|--|
| 1005 | Stationary RTK reference station antenna reference point |
| 1006 | Stationary RTK reference station ARP with antenna height |
| 1033 | Receiver and antenna description |
| 1074 | GPS MSM4 |
| 1075 | GPS MSM5 |
| 1076 | GPS MSM6 |
| 1077 | GPS MSM7 |
| 1084 | GLONASS MSM4 |
| 1085 | GLONASS MSM5 |
| 1086 | GLONASS MSM6 |
| 1087 | GLONASS MSM7 |
| 1094 | Galileo MSM4 |
| 1095 | Galileo MSM5 |
| 1096 | Galileo MSM6 |
| 1097 | Galileo MSM7 |
| 1114 | QZSS MSM4 |
| 1115 | QZSS MSM5 |
| 1116 | QZSS MSM6 |
| 1117 | QZSS MSM7 |
| 1124 | BeiDou MSM4 |

| | |
|------|-------------|
| 1125 | BeiDou MSM5 |
| 1126 | BeiDou MSM6 |
| 1127 | BeiDou MSM7 |
| 1134 | NavIC MSM4 |
| 1135 | NavIC MSM5 |
| 1136 | NavIC MSM6 |
| 1137 | NavIC MSM7 |

When operating in base mode, PX1105R can output following RTCM 3.3 messages:

| RTCM Message Type | Description |
|--------------------------|--|
| 1005 | Stationary RTK reference station antenna reference point |
| 1074 | GPS MSM4 |
| 1077 | GPS MSM7 |
| 1084 | GLONASS MSM4 |
| 1087 | GLONASS MSM7 |
| 1094 | Galileo MSM4 |
| 1097 | Galileo MSM7 |
| 1114 | QZSS MSM4 |
| 1117 | QZSS MSM7 |
| 1124 | BeiDou MSM4 |
| 1127 | BeiDou MSM7 |
| 1134 | NavIC MSM4 |
| 1137 | NavIC MSM7 |

PINOUT DESCRIPTION

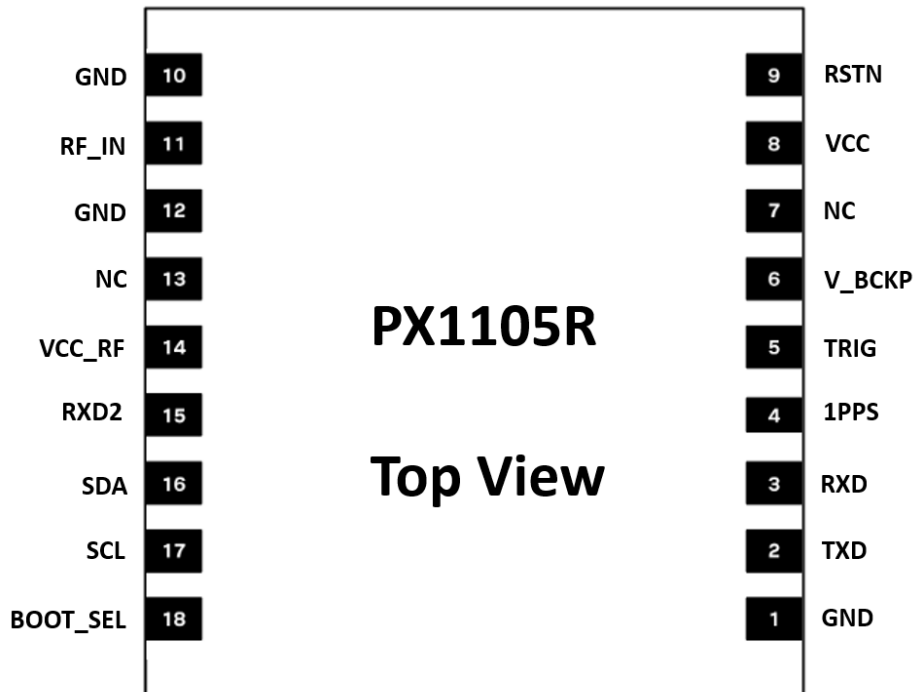

| Pin No. | Name | Description |
|---------|--------|---|
| 1 | GND | Ground |
| 2 | TXD | UART serial data output, 3.3V LVTTTL. One full-duplex asynchronous serial UART port is implemented. This UART output is normally used for sending position, time and velocity information from the receiver in NMEA-0183 format. When idle, this pin output HIGH. |
| 3 | RXD | UART serial data input, 3.3V LVTTTL. One full-duplex asynchronous serial UART port is implemented. This UART input is normally for sending commands or information to the receiver in SkyTraq binary protocol. In the idle condition, this pin should be driven HIGH. If the driving circuitry is powered independently of PX1100S, ensure that this pin is not driven to HIGH when primary power to PX1100S is removed, or a 10K-ohm series resistor can be added to minimize leakage current from application to the powered off module. |
| 4 | 1PPS | One-pulse-per-second (1PPS) time mark output, 3.3V LVTTTL. The rising edge synchronized to UTC second when getting 3D position fix. The pulse duration is about 100msec at rate of 1 Hz. |
| 5 | TRIG | External trigger, 3.3V LVTTTL. |
| 6 | V_BCKP | Backup supply voltage for internal RTC and backup SRAM, 1.3V ~ 3.6V. V_BCKP must be applied whenever VCC is applied. This pin should be powered continuously to minimize the startup time. If VCC and V_BCKP are both removed, the receiver will be in factory default mode upon power up, all user configuration set is lost. For applications the does not care cold starting every time, this pin can be connected to VCC. |
| 7 | NC | No connection, empty pin |
| 8 | VCC | Main power supply, 3.3V +/- 10% |

| | | |
|----|----------|--|
| 9 | RSTN | External active-low reset input to the baseband. Only needed when power supply rise time is very slow or software-controlled reset is desired. |
| 10 | GND | Ground |
| 11 | RF_IN | RF input with 3.3V active antenna bias voltage |
| 12 | GND | Ground |
| 13 | NC | No connection, empty pin |
| 14 | VCC_RF | Output voltage RF section |
| 15 | RXD2 | UART serial data input, 3.3V LVTTTL. One simplex asynchronous serial UART port is implemented. This UART input is normally for sending RTCM-SC104 correction data or base station SkyTraq raw measurement data to the receiver at 115200 baud rate. In the idle condition, this pin should be driven HIGH. If the driving circuitry is powered independently of PX1105R, ensure that this pin is not driven to HIGH when PX1105R is put to sleep, or a 10K-ohm series resistor can be added to minimize leakage current. |
| 16 | SDA | Not used. Leave unconnected |
| 17 | SCL | Not used. Leave unconnected |
| 18 | BOOT_SEL | No connection for normal use. Pull-low for loading firmware into empty or corrupted Flash memory from ROM mode. |

ELECTRICAL SPECIFICATIONS

ABSOLUTE MAXIMUM RATINGS

| Parameter | Minimum | Maximum | Condition |
|---------------------------------|---------|---------|-----------|
| Supply Voltage (VCC) | -0.5 | 3.6 | Volt |
| Backup Battery Voltage (V_BCKP) | -0.5 | 3.6 | Volt |
| Input Pin Voltage | -0.5 | VCC+0.5 | Volt |
| Input Power at RF_IN | | +5 | dBm |
| Storage Temperature | -55 | +100 | degC |

OPERATING CONDITIONS

| Parameter | Min | Typ | Max | Unit |
|--|-----|-----|-----|------|
| Supply Voltage (VCC) | 3 | 3.3 | 3.6 | Volt |
| Acquisition Current (exclude active antenna current) | | 115 | | mA |
| Tracking Current (exclude active antenna current) | | 95 | | mA |
| Backup Voltage (V_BCKP) | 1.3 | | 3.6 | Volt |
| Backup Current (VCC voltage applied) | | 54 | | uA |
| Backup Current (VCC voltage off) | | 13 | | uA |
| Output Low Voltage | | | 0.4 | Volt |
| Output HIGH Voltage | 2.4 | | | Volt |
| Input LOW Voltage | | | 0.8 | Volt |
| Input HIGH Voltage | 2 | | | Volt |
| Input LOW Current | -10 | | 10 | uA |
| Input HIGH Current | -10 | | 10 | uA |
| RF Input Impedance (RF_IN) | | 50 | | Ohm |

APPLICATION CIRCUIT

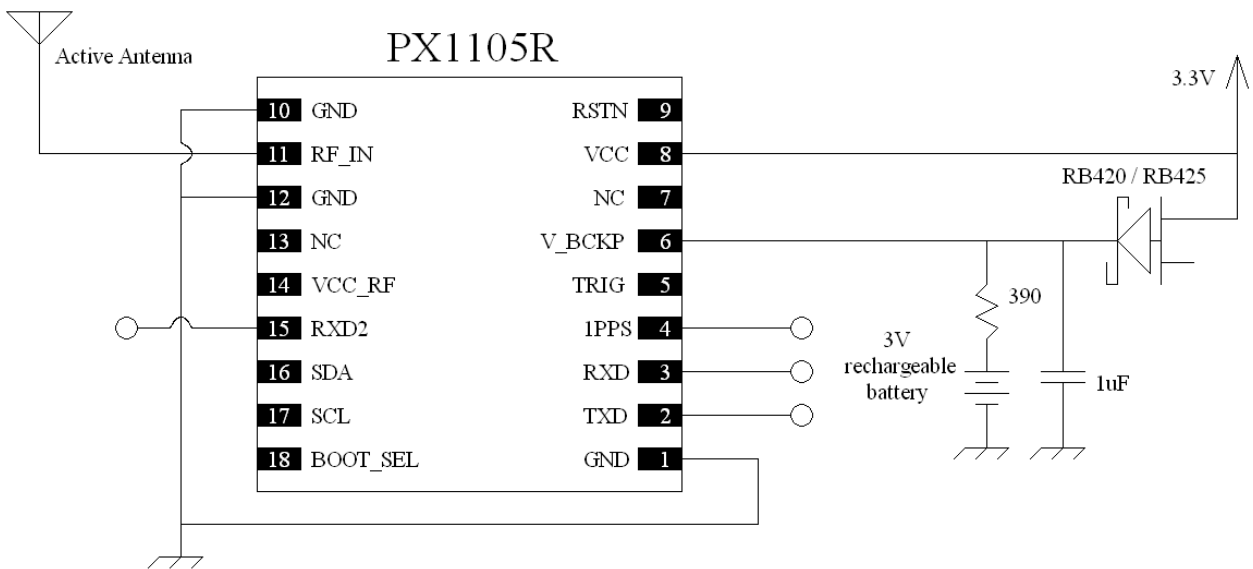

For Precise Positioning, Rover Mode Configuration 1

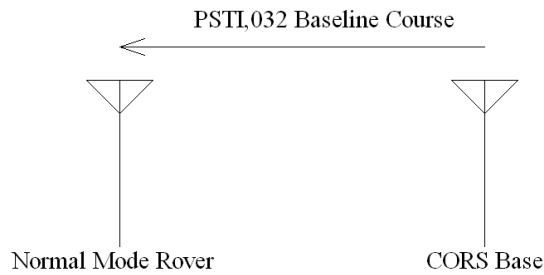
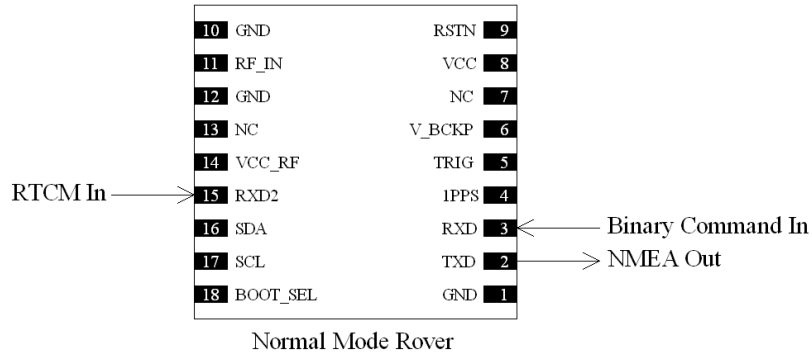

For Precise Positioning, Rover Mode Configuration 2

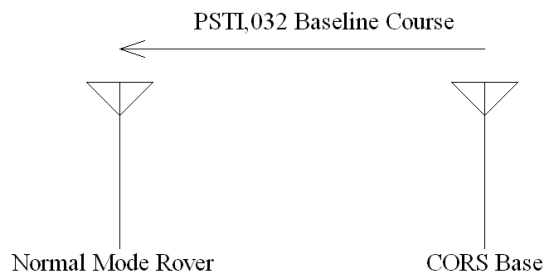
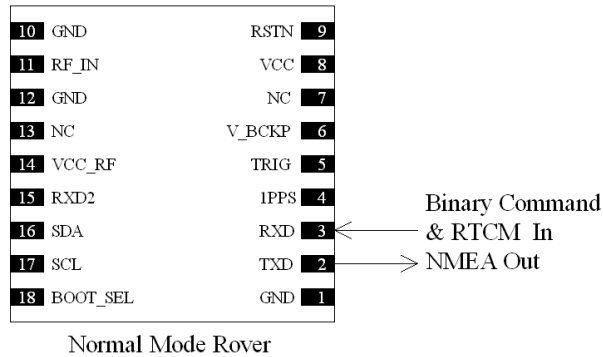

For Precise Heading, Moving Base Mode Configuration

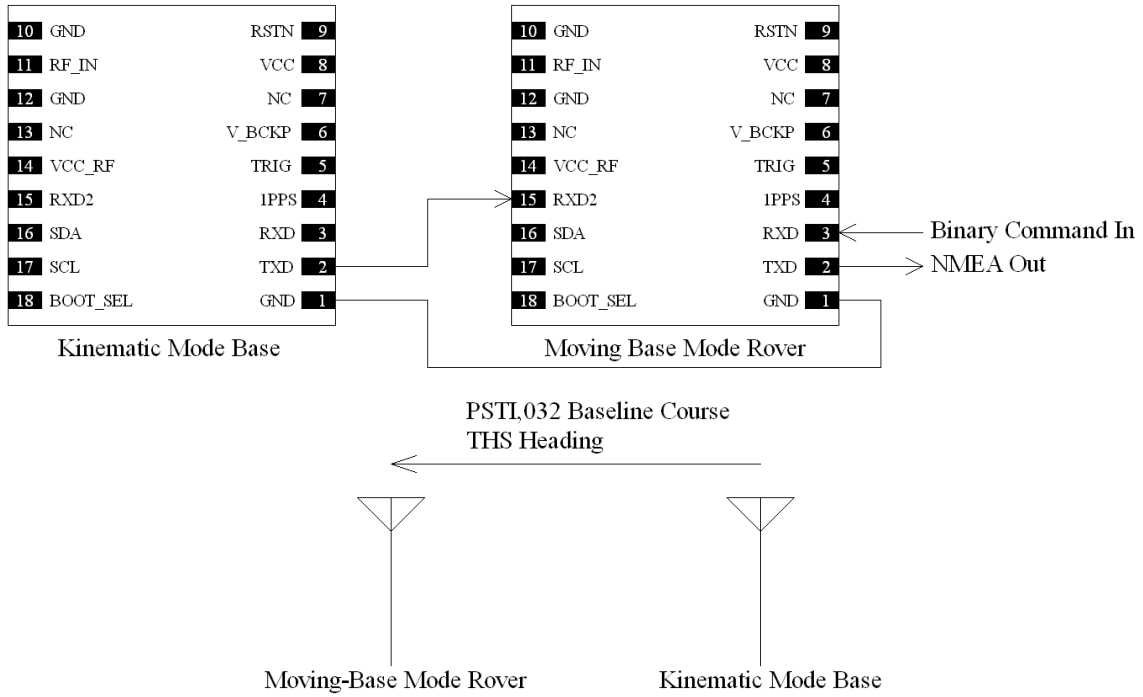

For Precise Positioning & Heading, Advanced Moving Base Mode Configuration #1

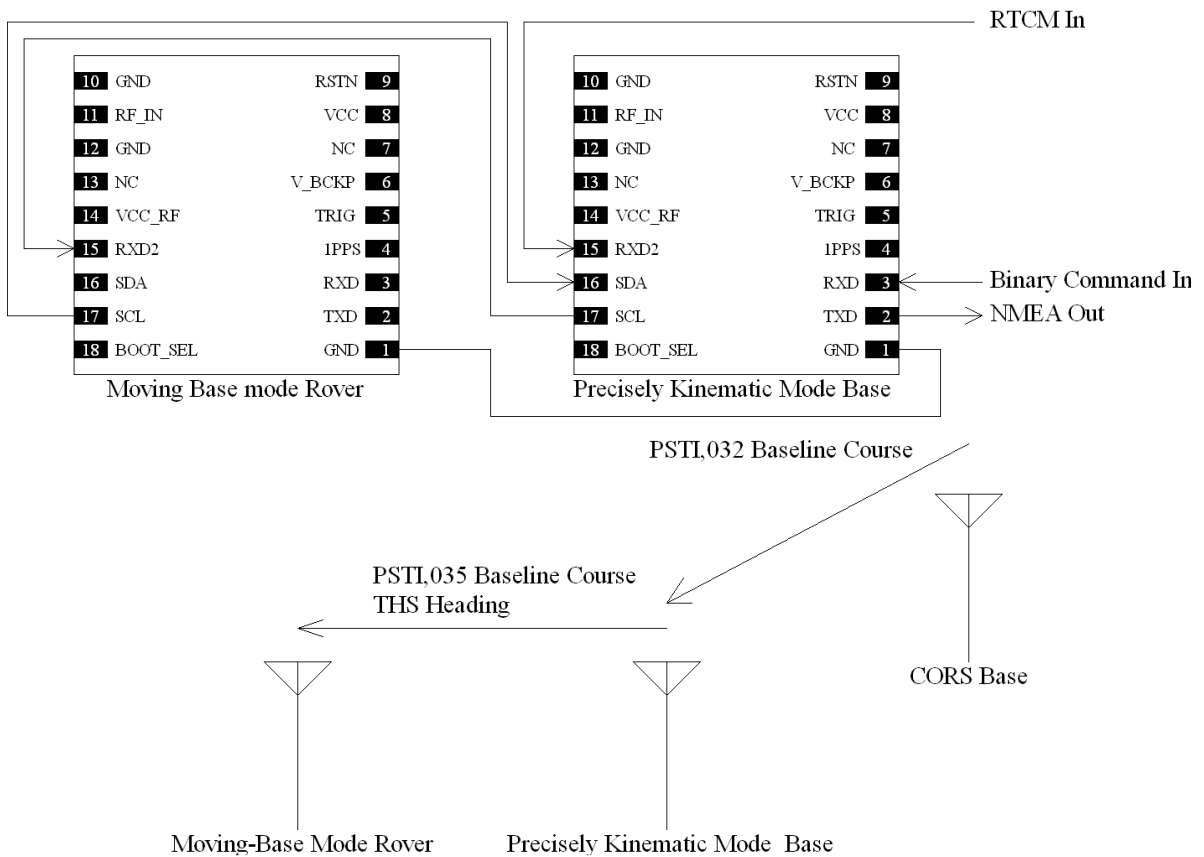

For Precise Positioning & Heading, Advanced Moving Base Mode Configuration #2

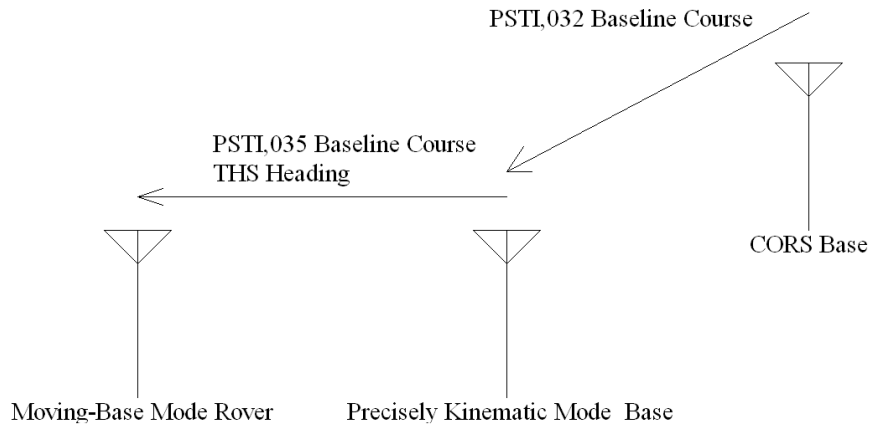
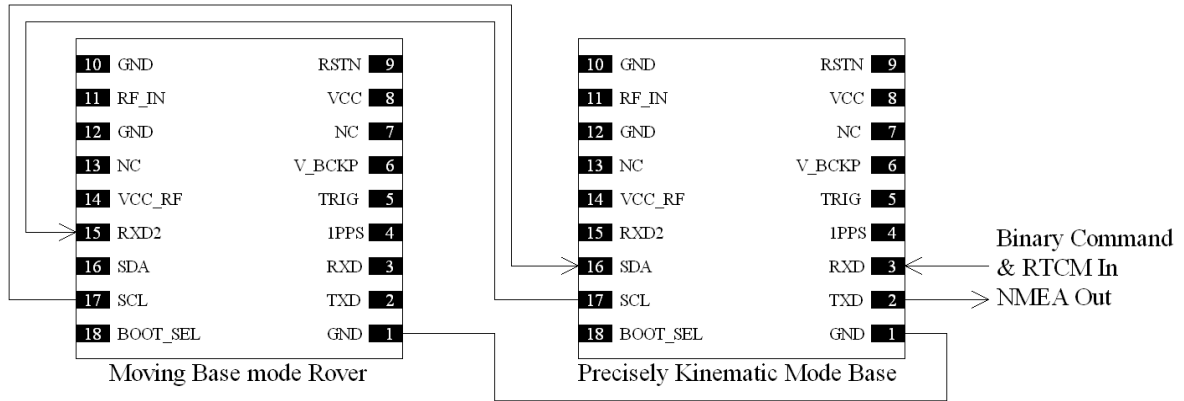

MECHANICAL DIMENSIONS

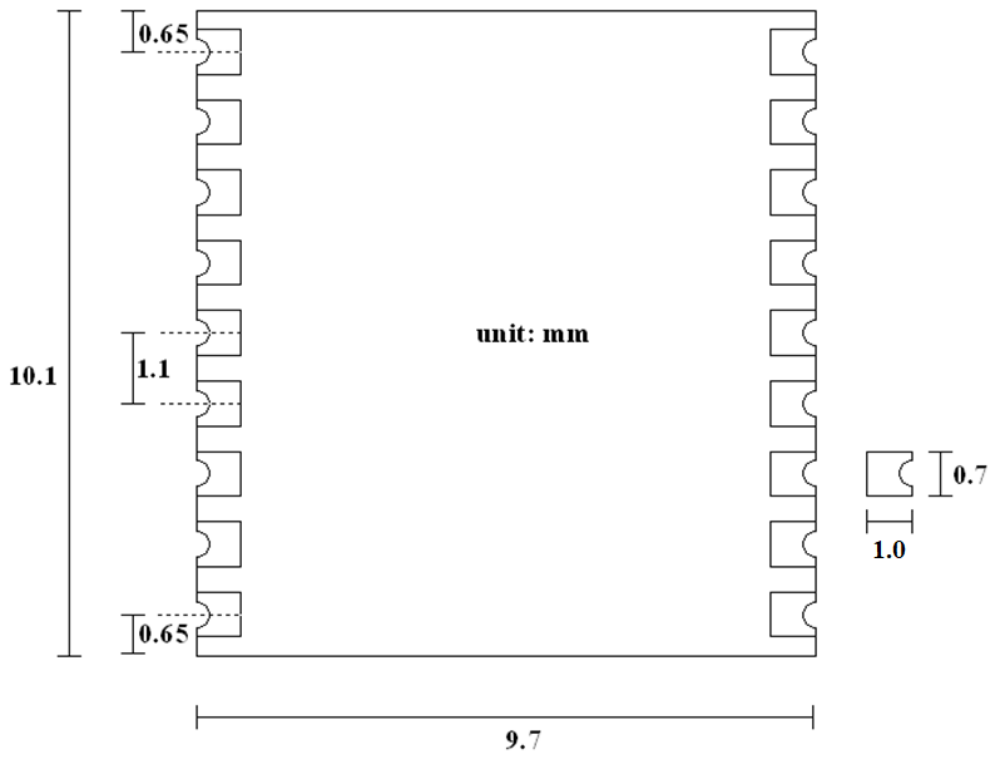

RECOMMENDED FOOTPRINT

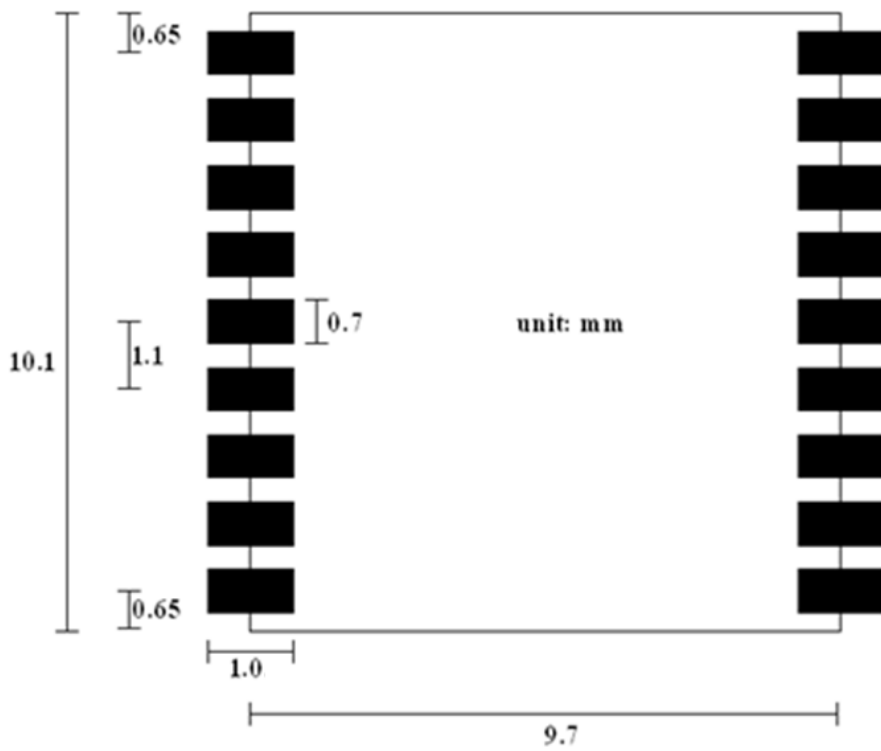

RECOMMENDED REFLOW PROFILE

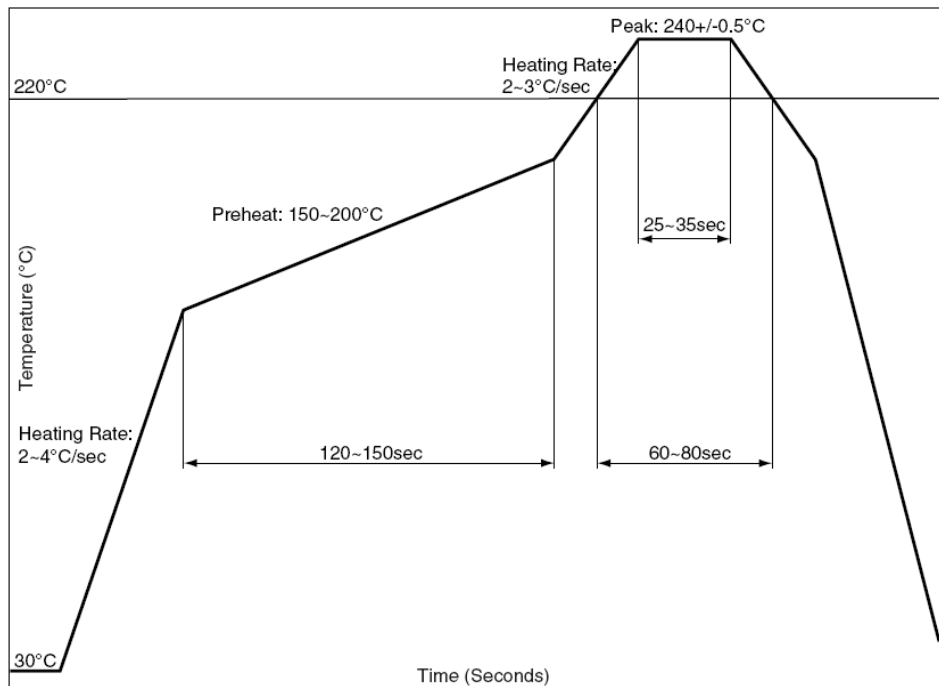

The reflow profile shown above should not be exceeded, since excessive temperatures or transport times during reflow can damage the module. Cooling temperature fall rate: max 3°C / sec

ANTENNA CONSIDERATIONS

The PX1105R is designed to be used with GPS/QZSS L1/L5, Galileo E1/E5a, BDS B1I/B2a, GLONASS L1, NavIC L5 dual band active antenna. Antenna with gain up to 40dB and noise figure less than 2dB can be used. It is important to select a high-performance antenna to achieve optimal RTK performance.

POWER SUPPLY REQUIREMENT

PX1105R requires a stable power supply, avoid ripple on VCC pin (<50mVpp). Power supply noise can affect the receiver's sensitivity. Bypass capacitors should be placed close to the module VCC pin, with values adjusted depending on the amount and type of noise present on the supply line.

BACKUP SUPPLY

The purpose of backup supply voltage pin (V_BCKP) is to keep the SRAM memory and the RTC powered when the module is powered down. This enables the module to have a faster time-to-first-fix when the module is powered on again. The backup current drain is less than 55µA. In normal powered on state, the internal processor access the SRAM and current drain is higher in active mode

1PPS OUTPUT

A 1 pulse per second signal (100msec HIGH duration) is generated on 1PPS pin when the receiver has 3D position fix using 4 or more satellites. The rising edge of the pulse is aligned with UTC second, with accuracy of about 10nsec. It outputs constant LOW when no position fix is available initially.

LAYOUT GUIDELINES

Separate RF and digital circuits into different PCB regions.

It is necessary to maintain 50-ohm impedance throughout the entire RF signal path. Try keeping the RF signal path as short as possible.

Do not route the RF signal line near noisy sources such as digital signals, oscillators, switching power supplies, or other RF transmitting circuit. Do not route the RF signal under or over any other components (including PX1105R), or other signal traces. Do not route the RF signal path on an inner layer of a multi-layer PCB to minimize signal loss.

Avoid sharp bends for RF signal path. Make two 45-deg bends or a circular bend instead of a single 90-degree bend if needed.

Avoid vias with RF signal path whenever possible. Every via adds inductive impedance. Vias are acceptable for connecting the RF grounds between different layers. Each of the module's ground pins should have short trace tying immediately to the ground plane below through a via.

The bypass capacitors should be low ESR ceramic types and located directly adjacent to the pin they are for.

HANDLING GUIDELINE

The PX1105R modules are rated MSL4, must be used for SMT reflow mounting within 72 hours after taken out from the vacuumed ESD-protective moisture barrier bag in factory condition < 30degC / 60% RH. If this floor life time is exceeded, or if the received ESD-protective moisture barrier bag is not in vacuumed state, then the device need to be pre-baked before SMT reflow process. Baking is to be done at 85degC for 8 to 12 hours. Once baked, floor life counting begins from 0, and has 72 hours of floor life at factory condition < 30degC / 60% RH.

PX1105R module is ESD sensitive device and should be handled with care.

RTK Usage Guideline

Below conditions are required for getting RTK fix solution. If the conditions are not met, PX1105R will only have float or DGPS/3D solution and behave like a normal GNSS receiver.

- * Base and rover distance under 30Km
- * Open sky environment without interference
- * Signal over 37dB/Hz
- * 8 or more satellites above 15 degree elevation angle with good satellite geometry or low DOP value; generally more satellites will have faster RTK fix

NMEA Output Description

The output protocol supports NMEA-0183 standard. The implemented messages include GGA, GLL, GSA, GSV, VTG, RMC, ZDA and GNS messages. The NMEA message output has the following sentence structure:

\$aacc,c-c*hh<CR><LF>

The detail of the sentence structure is explained in Table 1.

Table 1: The NMEA sentence structure

| character | HEX | Description |
|-----------|------|---|
| "\$" | 24 | Start of sentence. |
| Aacc | | Address field. "aa" is the talker identifier. "ccc" identifies the sentence type. |
| "," | 2C | Field delimiter. |
| C-c | | Data sentence block. |
| "*" | 2A | Checksum delimiter. |
| Hh | | Checksum field. |
| <CR><LF> | 0D0A | Ending of sentence. (carriage return, line feed) |

Table 2: Overview of SkyTraq receiver's NMEA messages

| | |
|--|---|
| \$GPGGA | Time, position, and fix related data of the receiver. |
| \$GNGLL | Position, time and fix status. |
| \$GNGSA | Used to represent the ID's of satellites which are used for position fix. When GPS satellites are used for position fix, \$GNGSA sentence is output with system ID 1. When GLONASS satellites are used for position fix, \$GNGSA sentence is output with system ID 2. When Galileo satellites are used for position fix, \$GNGSA sentence is output with system ID 3. When BDS satellites are used for position fix, \$GNGSA sentence is output with system ID 4. When NAVIC satellites are used for position fix, \$GNGSA sentence is output with system ID 6. |
| \$GPGSV \$GLGSV \$GAGSV \$GBGSV \$GIGSV | Satellite information about elevation, azimuth and CNR, \$GPGSV is used for GPS satellites, \$GLGSV is used for GLONASS satellites, \$GAGSV is used for GALILEO satellites, while \$GBGSV is used for BDS satellites, while \$GIGSV is used for NAVIC satellites |
| \$GNRMC | Time, date, position, course and speed data. |
| \$GNVTG | Course and speed relative to the ground. |
| \$GNZDA | UTC, day, month and year and time zone. |
| \$GNTHS | True Heading and Status. |

The formats of the supported NMEA messages are described as follows:

GGA – Global Positioning System Fix Data

Time, position and fix related data for a GPS receiver.

Structure:

\$GPGGA,hhmmss.sss,ddmm.mmmmmmm,a,dddmm.mmmmmmm,a,x,xx,x.x,x.x,M,x.x,M,x.x,xxxx*hh<CR><LF>
 1 2 3 4 5 6 7 8 9 10 11 12

Example:

\$GPGGA,072120.000,2447.0913289,N,12100.5212111,E,4,27,0.5,94.715,M,19.600,M,2.000,0000*49<CR><LF>

| Field | Name | Example | Description |
|-------|------------------------------|---------------|--|
| 1 | UTC Time | 072120.000 | UTC of position in hhmmss.sss format, (000000.000 ~ 235959.999) |
| 2 | Latitude | 2447.0913289 | Latitude in ddmm.mmmmmmm format Leading zeros transmitted |
| 3 | N/S Indicator | N | Latitude hemisphere indicator, 'N' = North, 'S' = South |
| 4 | Longitude | 12100.5212111 | Longitude in dddmm.mmmmmmm format Leading zeros transmitted |
| 5 | E/W Indicator | E | Longitude hemisphere indicator, 'E' = East, 'W' = West |
| 6 | GPS quality indicator | 4 | GPS quality indicator 0: position fix unavailable 1: valid position fix, SPS mode 2: valid position fix, differential GPS mode 3: GPS PPS Mode, fix valid 4: Real Time Kinematic. System used in RTK mode with fixed integers 5: Float RTK. Satellite system used in RTK mode., floating integers 6: Estimated (dead reckoning) Mode 7: Manual Input Mode 8: Simulator Mode |
| 7 | Satellites Used | 27 | Number of satellites in use, (00 ~ 12) |
| 8 | HDOP | 0.5 | Horizontal dilution of precision, (0.0 ~ 99.9) |
| 9 | Altitude | 94.715 | mean sea level (geoid), (-9999.9 ~ 17999.9) |
| 10 | Geoidal Separation | 19.600 | Geoidal separation in meters |
| 11 | Age of Differential GPS data | 2.000 | Age of Differential NULL when not in RTK fix or RTK float |
| 12 | DGPS Station ID | 0000 | Differential reference station ID, 0000 ~ 1023 |
| 13 | Checksum | 49 | |

GLL – Latitude/Longitude

Latitude and longitude of current position, time, and status.

Structure:

\$GNGLL,ddmm.mmmmmmm,a,dddmm.mmmmmmm,a,hmmss.sss,A,a*hh<CR><LF>
1 2 3 4 5 6 7 8

Example:

\$GNGLL,2447.0913289,N,12100.5212111,E,072120.000,A,D*4E<CR><LF>

| Field | Name | Example | Description |
|-------|----------------|---------------|--|
| 1 | Latitude | 2447.0913289 | Latitude in ddmm.mmmmmmm format Leading zeros transmitted |
| 2 | N/S Indicator | N | Latitude hemisphere indicator 'N' = North 'S' = South |
| 3 | Longitude | 12100.5212111 | Longitude in dddmm.mmmmmmm format Leading zeros transmitted |
| 4 | E/W Indicator | E | Longitude hemisphere indicator 'E' = East 'W' = West |
| 5 | UTC Time | 072120.000 | UTC time in hhmmss.sss format (000000.000 ~ 235959.999) |
| 6 | Status | A | Status, 'A' = Data valid, 'V' = Data not valid |
| 7 | Mode Indicator | D | Mode indicator 'A' = Autonomous mode 'D' = Differential mode 'E' = Estimated (dead reckoning) mode 'M' = Manual input mode 'S' = Simulator mode 'N' = Data not valid |
| 8 | Checksum | 4E | |

GSA – GNSS DOP and Active Satellites

GNSS receiver operating mode, satellites used in the navigation solution reported by the GGA or GNS sentence and DOP values.

Structure:

```
$GNGSA,A,x,xx,xx,xx,xx,xx,xx,xx,xx,xx,xx,xx,x.x,x.x,x.x,x*hh<CR><LF>
  1 2 3 3 3 3 3 3 3 3 3 3 3 4 5 6 7 8
```

Example:

```
$GNGSA,A,3,02,05,06,12,13,19,20,193,195,199,,,1.0,0.5,0.9,1*01<CR><LF>
$GNGSA,A,3,03,05,09,36,,,,,,,,,1.0,0.5,0.9,3*34<CR><LF>
$GNGSA,A,3,06,07,08,09,10,19,22,29,35,38,39,40,1.0,0.5,0.9,4*38<CR><LF>
$GNGSA,A,3,44,,,,,,,,,1.0,0.5,0.9,4*39<CR><LF>
$GNGSA,A,3,02,03,,,,,,,,,1.1,0.5,1.0,6*33<CR><LF>
```

| Field | Name | Example | Description |
|-------|---------------------|----------------------------------|---|
| 1 | Mode | A | Mode 'M' = Manual, forced to operate in 2D or 3D mode 'A' = Automatic, allowed to automatically switch 2D/3D |
| 2 | Mode | 3 | Fix type 1 = Fix not available 2 = 2D 3 = 3D |
| 3 | Satellite used 1~12 | 02,05,06,12,13,19,20,193,195,199 | 01 ~ 32 are for GPS; 33 ~ 64 are for WAAS (PRN minus 87); 193 ~ 197 are for QZSS; 65 ~ 88 are for GLONASS (GL PRN) ; 01 ~ 36 are for GALILEO (GA PRN); 01 ~ 37 are for BDS (BD PRN). GPS, GLONASS, GALILEO and BDS satellites are differentiated by the GNSS system ID in table 3. Maximally 12 satellites are included in each GSA sentence. |
| 4 | PDOP | 1.0 | Position dilution of precision (0.0 to 99.9) |
| 5 | HDOP | 0.5 | Horizontal dilution of precision (0.0 to 99.9) |
| 6 | VDOP | 0.9 | Vertical dilution of precision (0.0 to 99.9) |
| 7 | GNSS System ID | 1 | GNSS system ID* 1 = GPS 2 = GLONASS 3 = GALILEO 4 = BDS 6 = IRNSS |
| 8 | Checksum | 01 | |

*GNSS System ID identifies the GNSS system ID according to Table 3.

*GNSS Signal ID identifies the GNSS signal name according to Table 3.

Table 3: GNSS Identification Table for GSA, GSV

| System | System ID (Talker) | Signal ID | Signal Name |
|---------|--------------------|-----------|-----------------|
| GPS | 1 (GP) | 0 | All signals |
| | | 1 | L1 C/A |
| | | 2 | L1 P(Y) |
| | | 3 | L1C |
| | | 4 | L2 P(Y) |
| | | 5 | L2C-M |
| | | 6 | L2C-L |
| | | 7 | L5-I |
| | | 8 | L5-Q |
| GLONASS | 2 (GL) | 0 | All signals |
| | | 1 | G1 C/A |
| | | 2 | G1P |
| | | 3 | G2 C/A |
| | | 4 | GLONASS (M) G2P |
| GALILEO | 3 (GA) | 0 | All signals |
| | | 1 | E5a |
| | | 2 | E5b |
| | | 3 | E5 a+b |
| | | 4 | E6-A |
| | | 5 | E6-BC |
| | | 6 | L1-A |
| | | 7 | L1-BC |
| BDS | 4 (BD) | 0 | All signals |
| | | 1 | B1 |
| | | 5 | B2A |
| | | B | B2 |
| | | 8 | B3 |
| | | 3 | B1C |
| IRNSS | 6 (GI) | 0 | All signals |
| | | 1 | L5 |

GSV – GNSS Satellites in View

Number of satellites (SV) in view, satellite ID numbers, elevation, azimuth, and SNR value. Four satellites maximum per transmission.

Structure:

```
$GPGSV,x,x,xx,xx,xx,xxx,xx,...,xx,xx,xxx,xx,x *hh<CR><LF>
  1 2 3 4 5 6 7 4 5 6 7 8 9
```

Example:

```
$GPGSV,3,1,11,195,73,125,46,193,71,078,46,199,60,166,41,02,56,002,46,1*59<CR><LF>
$GPGSV,3,2,11,11,54,011,45,20,53,298,47,06,46,061,45,05,40,268,45,1*6F<CR><LF>
$GPGSV,3,3,11,19,36,148,45,13,27,186,41,12,23,260,43,1*59<CR><LF>
$GPGSV,1,1,04,195,73,125,44,193,71,078,43,199,60,166,45,06,46,061,45,8*56<CR><LF>
$GAGSV,2,1,07,05,74,099,45,18,58,157,48,36,48,080,43,03,39,201,43,7*70<CR><LF>
$GAGSV,2,2,07,09,29,043,36,02,10,211,,11,07,112,,7*40<CR><LF>
$GAGSV,2,1,05,05,74,099,43,18,58,157,46,36,48,080,42,03,39,201,43,1*7D<CR><LF>
$GAGSV,2,2,05,09,29,043,37,1*41<CR><LF>
$GBGSV,4,1,13,35,78,358,50,22,60,245,50,19,58,025,48,38,53,351,46,1*75<CR><LF>
$GBGSV,4,2,13,08,49,356,41,29,43,129,47,06,36,170,42,40,35,211,44,1*74<CR><LF>
$GBGSV,4,3,13,10,35,224,43,39,31,181,44,07,28,198,42,44,25,322,40,1*7C<CR><LF>
$GBGSV,4,4,13,09,16,189,37,1*4E<CR><LF>
$GBGSV,2,1,08,35,78,358,43,22,60,245,45,19,58,025,44,38,53,351,42,5*73<CR><LF>
$GBGSV,2,2,08,29,43,129,42,40,35,211,41,39,31,181,40,44,25,322,36,5*7A<CR><LF>
$GIGSV,2,1,07,03,37,239,44,02,25,278,41,04,00,000,44,09,00,000,33,1*76<CR><LF>
$GIGSV,2,2,07,07,00,000,46,05,00,000,45,01,00,000,39,1*40<CR><LF>
```

| Field | Name | Example | Description |
|-------|--------------------|---------|--|
| 1 | Number of message | 3 | Total number of GSV messages to be transmitted (1-5) |
| 2 | Sequence number | 1 | Sequence number of current GSV message |
| 3 | Satellites in view | 11 | Total number of satellites in view (00 ~ 20) |
| 4 | Satellite ID | 195 | 01 ~ 32 are for GPS; 33 ~ 64 are for WAAS (PRN minus 87); 193 ~ 197 are for QZSS; 65 ~ 88 are for GLONASS (GL PRN) ; 01 ~ 36 are for GALILEO (GA PRN); 01 ~ 37 are for BDS (BD PRN). GPS, GLONASS, GALILEO and BDS satellites are differentiated by the GNSS system ID in table 3. Maximally 4 satellites are included in each GSV sentence. |
| 5 | Elevation | 73 | Satellite elevation in degrees, (00 ~ 90) |
| 6 | Azimuth | 125 | Satellite azimuth angle in degrees, (000 ~ 359) |
| 7 | SNR | 46 | C/No in dB (00 ~ 99) Null when not tracking |
| 8 | Signal ID | 1 | Signal ID* |
| 9 | Checksum | 59 | |

RMC – Recommended Minimum Specific GNSS Data

Time, date, position, course and speed data provided by a GNSS navigation receiver.

Structure:

\$GPRMC,hhmmss.sss,A,dddmm.mmmmmmm,a,dddmm.mmmmmmm,a,x.x,x.x,ddmmyy,,,a,a*hh<CR><LF>
 1 2 3 4 5 6 7 8 9 10 11 12

Example:

\$GNRMC,072120.000,A,2447.0913289,N,12100.5212111,E,000.0,000.0,050721,,,R,V*14<CR><LF>

| Field | Name | Example | Description |
|-------|--------------------|---------------|--|
| 1 | UTC time | 072120.000 | UTC time in hhmmss.sss format (000000.00 ~ 235959.999) |
| 2 | Status | A | Status 'V' = Navigation receiver warning 'A' = Data Valid |
| 3 | Latitude | 2447.0913289 | Latitude in dddmm.mmmmmmm format Leading zeros transmitted |
| 4 | N/S indicator | N | Latitude hemisphere indicator 'N' = North 'S' = South |
| 5 | Longitude | 12100.5212111 | Longitude in dddmm.mmmmmmm format Leading zeros transmitted |
| 6 | E/W Indicator | E | Longitude hemisphere indicator 'E' = East 'W' = West |
| 7 | Speed over ground | 000.0 | Speed over ground in knots (000.0 ~ 999.9) |
| 8 | Course over ground | 000.0 | Course over ground in degrees (000.0 ~ 359.9) |
| 9 | UTC Date | 050721 | UTC date of position fix, ddmmyy format |
| 10 | Mode indicator | R | Mode indicator 'A' = Autonomous mode 'D' = Differential mode 'E' = Estimated (dead reckoning) mode 'F' = Float RTK. Satellite system used in RTK mode, floating integers 'M' = Manual Input Mode 'N' = Data not valid 'P' = Precise 'R' = Real Time Kinematic. System used in RTK mode with fixed integers 'S' = Simulator Mode |
| 11 | Navigation status | V | Navigation status indicator according to IEC61108 requirement on 'Navigational (or Failure) warnings and status indicators'. 'S' = Safe 'C' = Caution 'U' = Unsafe 'V' = Navigation status not valid, equipment is not providing navigation status indicator. |
| 12 | checksum | 14 | |

VTG – Course Over Ground and Ground Speed

The actual course and speed relative to the ground.

Structure:

GPVTG,x.x,T,,M,x.x,N,x.x,K,a*hh<CR><LF>
 1 2 3 4 5

Example:

\$GNVTG,000.0,T,,M,000.0,N,000.0,K,D*16<CR><LF>

| Field | Name | Example | Description |
|-------|----------|---------|---|
| 1 | Course | 000.0 | True course over ground in degrees (000.0 ~ 359.9) |
| 2 | Speed | 000.0 | Speed over ground in knots (000.0 ~ 999.9) |
| 3 | Speed | 000.0 | Speed over ground in kilometers per hour (000.0 ~ 1800.0) |
| 4 | Mode | D | Mode indicator 'A' = Autonomous mode 'D' = Differential mode 'E' = Estimated (dead reckoning) mode 'M' = Manual input mode 'N' = Data not valid 'P' = Precise 'S' = Simulator mode |
| 5 | Checksum | 16 | |

ZDA – TIME AND DATE

UTC, day, month, year and local time zone

Structure:

\$GPZDA,hhmmss.sss,xx,xx,xxxx,xx,xx*hh<CR><LF>
 1 2 3 4 5 6 7

Example:

\$GNZDA,072120.000,05,07,2021,00,00*4D<CR><LF>

| Field | Name | Example | Description |
|-------|--------------------|------------|---|
| 1 | UTC time | 072120.000 | UTC time in hhmmss.ss format (000000.00 ~ 235959.999) |
| 2 | UTC Day | 05 | UTC time: day (01 ~ 31) |
| 3 | UTC Month | 07 | UTC time: month (01 ~ 12) |
| 4 | UTC Year | 2021 | UTC time: year (4 digit format) |
| 5 | Local zone hour | 00 | Local zone hours (00 ~ +/- 13) |
| 6 | Local zone minutes | 00 | Local zone minutes (00 ~59) |
| 7 | Checksum | 4D | Checksum |

THS – True Heading and Status

Actual vessel heading in degrees True produced by any device or system producing true heading. This sentence includes a “Mode indicator” field providing critical safety related information about the heading data, and replaces the HDT sentence.

Structure:

\$GP^{THS}, x.x,a*hh<CR><LF>
1 2 3

Example:

\$GN^{THS}, 349.10.A*34<CR><LF>

| Field | Name | Example | Description |
|-------|----------|---------|---|
| 1 | Heading | 349.10 | Heading, degrees True |
| 2 | Mode | A | Mode indicator 'A' = Autonomous 'E' = Estimated (dead reckoning) 'M' = Manual input 'S' = Simulator 'V' = Data not valid |
| 3 | Checksum | 34 | Checksum |

STI,005 – Time Stamp Output

An output message, ID 0x005, contains module pin-4 event-triggered time stamp. The trigger input should be spaced more than 1msec apart, not more than 10 triggers between update rate interval.

Structure:

```
$PSTI,005,hhmmss.ssssss,xx,xx,xxxx,,,,*hh<CR><LF>
```

1 2 3 4 5 11

Example:

```
$PSTI,005,072120.0000003,05,07,2021,,,,*33<CR><LF>
```

| Field | Name | Example | Description |
|-------|-----------|----------------|---|
| 1 | ID | 005 | Proprietary NMEA message identifier |
| 2 | UTC time | 072120.0000003 | Time-stamp UTC time in hhmmss.ssssss format (000000.0000000 ~ 235959.9999999) |
| 3 | UTC Day | 05 | Time-stamp UTC time: day (01 ~ 31) |
| 4 | UTC Month | 07 | Time-stamp UTC time: month (01 ~ 12) |
| 5 | UTC Year | 2021 | Time-stamp UTC time: year (4 digit format) |
| 6 | Reserved | | |
| 7 | Reserved | | |
| 8 | Reserved | | |
| 9 | Reserved | | |
| 10 | Reserved | | |
| 11 | Checksum | 33 | Checksum |

STI,030– Recommended Minimum 3D GNSS Data

Time, date, position, course and speed data provided by a GNSS navigation receiver.

Structure:

\$PSTI,030,hhmss.sss,A,dddmm.mmmmmmm,a,dddmm.mmmmmmm,a,x.x,x.x,x.x,x.x,ddmmyy,a.x.x,x.x*hh<CR><LF>
 1 2 3 4 5 6 7 8 9 10 11 12 13 14 15

Example:

\$PSTI,030,072120.000,A,2447.0913289,N,12100.5212111,E,94.715,0.00,-0.00,0.02,050721,R,2.000,10.000*28
 <CR><LF>

| Field | Name | Example | Description |
|-------|----------------|---------------|--|
| 1 | UTC time | 072120.000 | UTC time in hhmss.sss format (000000.00 ~ 235959.999) |
| 2 | Status | A | Status 'V' = Navigation receiver warning 'A' = Data Valid |
| 3 | Latitude | 2447.0913289 | Latitude in dddmm.mmmmmmm format Leading zeros transmitted |
| 4 | N/S indicator | N | Latitude hemisphere indicator 'N' = North 'S' = South |
| 5 | Longitude | 12100.5212111 | Longitude in dddmm.mmmmmmm format Leading zeros transmitted |
| 6 | E/W Indicator | E | Longitude hemisphere indicator 'E' = East 'W' = West |
| 7 | Altitude | 94.715 | mean sea level (geoid), (-9999.999 ~ 17999.999) |
| 8 | East Velocity | 0.00 | 'East' component of ENU velocity (m/s) |
| 9 | North Velocity | -0.00 | 'North' component of ENU velocity (m/s) |
| 10 | Up Velocity | 0.02 | 'Up' component of ENU velocity (m/s) |
| 11 | UTC Date | 050721 | UTC date of position fix, ddmmyy format |
| 12 | Mode indicator | R | Mode indicator 'A' = Autonomous mode 'D' = Differential mode 'E' = Estimated (dead reckoning) mode 'F' = Float RTK. Satellite system used in RTK mode, floating integers 'M' = Manual input mode 'N' = Data not valid 'P' = Precise 'R' = Real Time Kinematic. System used in RTK mode with fixed integers 'S' = Simulator mode |
| 13 | RTK Age | 2.000 | Age of differential |
| 14 | RTK Ratio | 10.000 | AR ratio factor for validation |
| 15 | Checksum | 28 | |

STI,032– RTK Baseline Data

Time, date, status and baseline related data provided by a GNSS navigation receiver.

Structure:

\$PSTI,032,hhmmss.sss,ddmmyy,A,R,x.xxx,x.xxx,x.xxx,x.xxx,x.xx,,,,,*hh<CR><LF>
 1 2 3 4 5 6 7 8 9

Example:

\$PSTI,032,072120.000,050721,A,R,-1.821,9.457,0.634,9.651,349.10,,,,*3A

| Field | Name | Example | Description |
|-------|------------------------------|------------|--|
| 1 | UTC time | 072120.000 | UTC time in hhmmss.sss format (000000.000~235959.999) |
| 2 | UTC Date | 050721 | UTC date of position fix, ddmmyy format |
| 3 | Status | A | Status 'V' = Void 'A' = Active |
| 4 | Mode indicator | R | Mode indicator 'F' = Float RTK. System used in RTK mode with float ambiguity 'R' = Real Time Kinematic. System used in RTK mode with fixed ambiguity |
| 5 | East-projection of baseline | -1.821 | East-projection of baseline, meters |
| 6 | North-projection of baseline | 9.457 | North-projection of baseline, meters |
| 7 | Up-projection of baseline | 0.634 | Up-projection of baseline, meters |
| 8 | Baseline length | 9.651 | Baseline length, meters |
| 9 | Baseline course | 349.10 | Baseline course (angle between baseline vector and north direction), degrees |
| 10 | Reserve | | Reserve |
| 11 | Reserve | | Reserve |
| 12 | Reserve | | Reserve |
| 13 | Reserve | | Reserve |
| 14 | Reserve | | Reserve |
| 15 | Checksum | 3A | |

STI,033– RTK RAW Measurement Monitoring Data

Time, date, and raw measurement monitoring data provided by a GNSS navigation receiver.

Structure:

\$PSTI,033,hhmmss.sss,ddmmyy,x,R,x,G,x,x,,,C,x,x,,,E,x,x,,,R,,,,,l,x,,, *hh <CR><LF>
 1 2 3 4 5 6 7 8 11 16 21

Example:

\$PSTI,033,072120.000,050721,2,R,0,G,0,0,,,C,0,0,,,E,0,0,,,R,,,,,l,0,,, *27

| Field | Name | Example | Description |
|-------|--|------------|--|
| 1 | UTC time | 072120.000 | UTC time in hhmmss.sss format (000000.000~235959.999) |
| 2 | UTC Date | 050721 | UTC date of position fix, ddmmyy format |
| 3 | Version | 2 | |
| 4 | Receiver | R | R – Rover; B – Base |
| 5 | Number of total cycle-slipped raw measurements | 0 | Number of total cycle-slipped raw measurements, this statistic is only summed by the measurements which are valid for RTK |
| 6 | Designate system type | G | GPS |
| 7 | Number of cycle-slipped raw measurements of designate signal type of GPS L1 | 0 | Number of cycle-slipped raw measurements of designate signal type of all satellite type, this statistic is only summed by the measurements which are valid for RTK |
| 8 | Number of cycle-slipped raw measurements of designate signal type of GPS L2 | 0 | Number of cycle-slipped raw measurements of designate signal type of all satellite type, this statistic is only summed by the measurements which are valid for RTK |
| 9 | Reserve for GPS frequency band | | Reserve |
| 10 | Reserve for GPS frequency band | | Reserve |
| 11 | Designate system type | C | BDS |
| 12 | Number of cycle-slipped raw measurements of designate signal type of BDS B1 | 0 | Number of cycle-slipped raw measurements of designate signal type of all satellite type, this statistic is only summed by the measurements which are valid for RTK |
| 13 | Number of cycle-slipped raw measurements of designate signal type of BDS B2 | 0 | Number of cycle-slipped raw measurements of designate signal type of all satellite type, this statistic is only summed by the measurements which are valid for RTK |
| 14 | Reserve for BDS frequency band | | Reserve |
| 15 | Reserve for BDS frequency band | | Reserve |
| 16 | Designate system type | E | Galileo |
| 17 | Number of cycle-slipped raw measurements of designate signal type of Galileo E1 | 0 | Number of cycle-slipped raw measurements of designate signal type of all satellite type, this statistic is only summed by the measurements which are valid for RTK |
| 18 | Number of cycle-slipped raw measurements of designate signal type of Galileo E5b | 0 | Number of cycle-slipped raw measurements of designate signal type of all satellite type, this statistic is only summed by the measurements which are valid for RTK |
| 19 | Reserve for Galileo frequency band | | Reserve |
| 20 | Reserve for Galileo frequency band | | Reserve |
| 21 | Designate system type | R | Glonass |
| 22 | Number of cycle-slipped raw measurements of designate signal type of Glonass G1 | | Number of cycle-slipped raw measurements of designate signal type of all satellite type, this statistic is only summed by the measurements which are valid for RTK |
| 23 | Number of cycle-slipped raw measurements of designate signal type of Glonass G2 | | Number of cycle-slipped raw measurements of designate signal type of all satellite type, this statistic is only summed by the measurements which are valid for RTK |

| | | | |
|----|---|----|--|
| 24 | Reserve for Glonass frequency band | | Reserve |
| 25 | Reserve for Glonass frequency band | | Reserve |
| 26 | Designate system type | I | NAVIC |
| 27 | Number of cycle-slipped raw measurements of designate signal type of NAVIC L5 | 0 | Number of cycle-slipped raw measurements of designate signal type of all satellite type, this statistic is only summed by the measurements which are valid for RTK |
| 28 | Reserve | | Reserve |
| 29 | Reserve | | Reserve |
| 20 | Reserve | | Reserve |
| 31 | Checksum | 27 | |

STI,035 – RTK Baseline Data of Rover Moving Base Receiver

Time, date, status and baseline related data of GNSS rover moving base receiver provided by GNSS precisely kinematic base receiver.

Structure:

\$PSTI,035,hhmmss.sss,ddmmyy,A,R,x.xxx,x.xxx,x.xxx,x.xxx,x.xx,,,,,*hh<CR><LF>
 1 2 3 4 5 6 7 8 9

Example:

\$PSTI,035,072120.000,050721,A,R,-1.821,9.457,0.634,9.651,349.10,,,,*3D

| Field | Name | Example | Description |
|-------|------------------------------|------------|--|
| 1 | UTC time | 072120.000 | UTC time in hhmmss.sss format (000000.000~235959.999) |
| 2 | UTC Date | 050721 | UTC date of position fix, ddmmyy format |
| 3 | Status | A | Status 'V' = Void 'A' = Active |
| 4 | Mode indicator | R | Mode indicator 'F' = Float RTK. System used in RTK mode with float ambiguity 'R' = Real Time Kinematic. System used in RTK mode with fixed ambiguity |
| 5 | East-projection of baseline | -1.821 | East-projection of baseline, meters |
| 6 | North-projection of baseline | 9.457 | North-projection of baseline, meters |
| 7 | Up-projection of baseline | 0.634 | Up-projection of baseline, meters |
| 8 | Baseline length | 9.651 | Baseline length, meters |
| 9 | Baseline course | 349.10 | Baseline course (angle between baseline vector and north direction), degrees |
| 10 | Reserve | | Reserve |
| 11 | Reserve | | Reserve |
| 12 | Reserve | | Reserve |
| 13 | Reserve | | Reserve |
| 14 | Reserve | | Reserve |
| 15 | Checksum | 3D | |

ORDERING INFORMATION

| Model Name | Description |
|------------|---|
| PX1105R | L1/L5 GNSS RTK Receiver Module GPS/QZSS L1/L5 + Galileo E1/E5a + Beidou B1/B2a + GLONASS L1 + NavIC L5 |
| PX1105R-01 | L1/L5 GNSS RTK Receiver Module GPS/QZSS L1/L5 + Galileo E1/E5a + Beidou B1/B2a + GLONASS L1 signal reception |

Revision History

| Revision | Date | Description |
|----------|-------------------|------------------------------|
| 1 | June 21, 2024 | Initial release |
| 2 | December 27, 2024 | Updated qualification status |

The information provided is believed to be accurate and reliable. These materials are provided to customers and may be used for informational purposes only. No responsibility is assumed for errors or omissions in these materials, or for its use. Changes to specification can occur at any time without notice.

These materials are provided "as is" without warranty of any kind, either expressed or implied, relating to sale and/or use including liability or warranties relating to fitness for a particular purpose, consequential or incidental damages, merchantability, or infringement of any patent, copyright or other intellectual property right. No warrant on the accuracy or completeness of the information, text, graphics or other items contained within these materials. No liability assumed for any special, indirect, incidental, or consequential damages, including without limitation, lost revenues or lost profits, which may result from the use of these materials.

The product is not intended for use in medical, life-support devices, or applications involving potential risk of death, personal injury, or severe property damage in case of failure of the product.