



NavIC + GAGAN / GPS SMD Receiver Module

Features

- L1 / L5 signal reception
- Works with NavIC, GAGAN, GPS
- Less than 30 second cold start TTFF
- ~ 1 second hot start
- ~2.5m CEP accuracy
- Multipath detection and suppression
- Works with passive and active antenna
- Complete receiver in 12.2mm x 16.0mm size
- Operating temperature -40 ~ +85°C
- Pb-free RoHS compliant

Applications

- Navigation and asset tracking
- Timing reference

The PX1125S-01 is a satellite navigation receiver capable of using NavIC L5, GAGAN L1, and GPS L1 signal to provide 3D navigation in a single compact SMD module. The PX1125S-01 can track all in-view GPS, GAGAN and NavIC satellites. It is fully autonomous such that once power is applied, the receiver automatically searches, acquires and tracks satellite signals. When a sufficient number of satellites are tracked with valid measurements, the receiver produces 3D position and velocity outputs.

NavIC + GPS dual-satellite capability enables using greater number of satellite signal than GPS-only receivers. The increased satellite number offers superior performance in challenging urban canyon and multipath environments.

The PX1125S-01 module contains single-chip Phoenix positioning engine inside, featuring high sensitivity and fast TTFF. PX1125S-01 can acquire, track, and get position fix autonomously in difficult weak signal environment. Its high tracking sensitivity allows continuous position coverage in nearly all outdoor application environments. The high performance signal parameter search engine is capable of testing 16 million time-frequency hypotheses per second, offering superior signal acquisition and TTFF speed.

TECHNICAL SPECIFICATIONS

Receiver Type	NavIC L5, GAGAN/GPS L1 C/A code Phoenix engine
Accuracy	Position 2.5m CEP Velocity 0.1m/sec Time 12nsec
Startup Time	~1sec hot start < 30sec cold start
Sensitivity	Better than -145 / -144dBm GPS / NavIC cold-start Better than -154 / -153dBm GPS / NavIC hot-start Better than -155 / -154dBm GPS / NavIC re-acquisition Better than -165 / -156dBm GPS / NavIC tracking
Multi-path Mitigation	Multi-path detection and suppression
A-GPS	7-day server-based AGPS Self-aided ephemeris estimation
Update Rate	1 / 2 / 4 / 5 / 8 / 10 Hz, default 1Hz
Dynamics	4G (39.2m/sec ²) acceleration
Operational Limits	Altitude < 80,000m and velocity < 515m/s, not exceeding both
Serial Interface	3.3V LVTTTL level UART, selectable 4800 ~ 115200 baud rate
Protocol	NMEA-0183 V3.01, SkyTraq binary, 115200 baud, 8, N, 1
Datum	Default WGS-84, User definable
Input Voltage	3.3V DC +/-10%
Current Consumption	80mA acquisition, 60mA tracking
Dimension	12.2mm W x 16.0mm L x 2.9mm H
Weight:	1.6g
Operating Temperature	-40°C ~ +85°C
Storage Temperature	-55°C ~ +100°C
Humidity	5% ~ 95%

BLOCK DIAGRAM

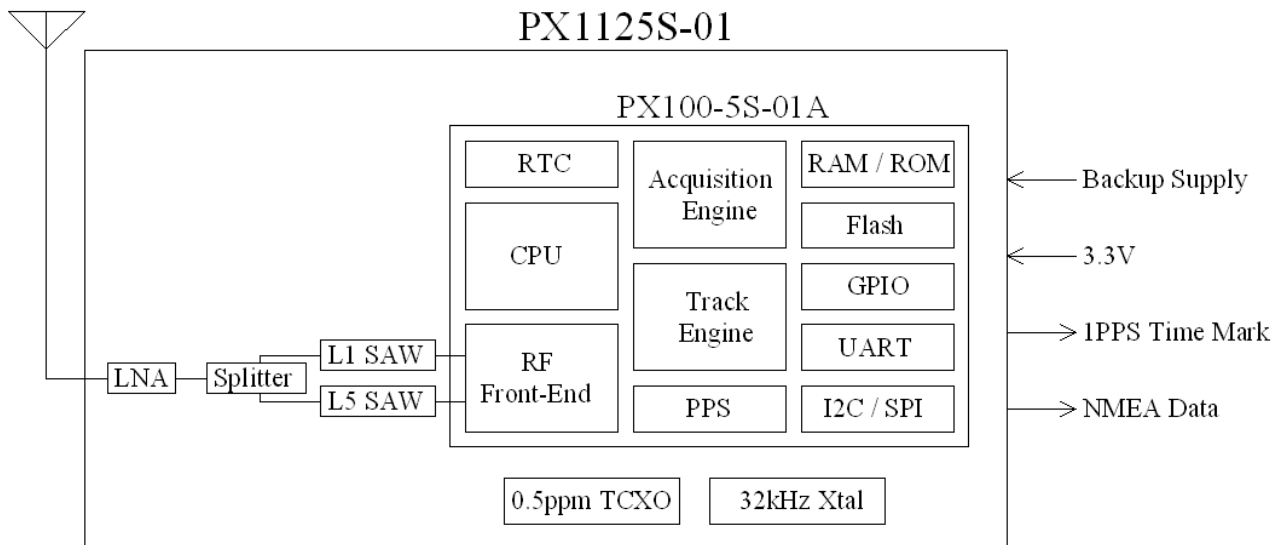

The PX1125S-01 is a L5 NavIC + L1 GAGAN/GPS satellite navigation receiver in a compact surface mount package. It is based on the latest single-chip Phoenix GNSS receiver technology, providing high performance signal acquisition and tracking. The simple UART serial interface and the standard NMEA-0183 protocol make usage of PX1125S-01 very easy and straightforward.

The PX1125S-01 module performs all the necessary system initialization, signal acquisition, signal tracking, data demodulation, and calculation of navigation solution autonomously.

MECHANICAL CHARACTERISTICS

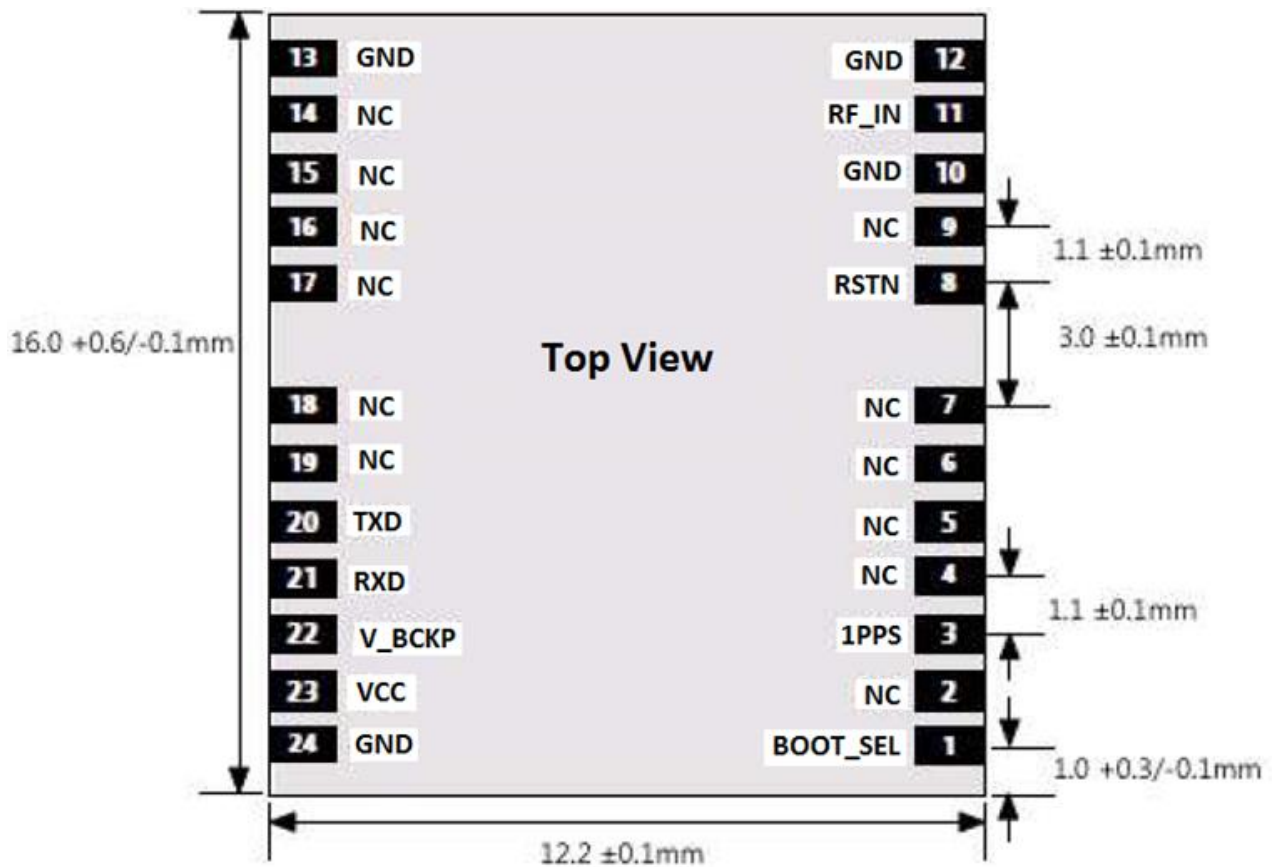

PINOUT DESCRIPTION

Pin No.	Name	Description
1	BOOT_SEL	No connection for normal use. Pull-low for loading firmware into empty or corrupted Flash memory from ROM mode.
2	NC	No connection, empty pin
3	1PPS	One-pulse-per-second (1PPS) time mark output, 3.3V LVTTTL. The rising edge synchronized to UTC second when getting 3D position fix. The pulse duration is about 100msec at rate of 1 Hz.
4	NC	No connection, empty pin
5	NC	No connection, empty pin
6	NC	No connection, empty pin
7	NC	No connection, empty pin
8	RSTN	External active-low reset input to the baseband. Only needed when power supply rise time is very slow or software controlled reset is desired.
9	NC	No connection, empty pin
10	GND	Ground
11	RF_IN	RF signal input, connect to L5 NavIC + L1 GPS antenna. 3.2V active antenna bias on RF IN.
12	GND	Ground
13	GND	Ground
14	NC	No connection, empty pin
15	NC	No connection, empty pin

16	NC	No connection, empty pin
17	NC	No connection, empty pin
18	NC	No connection, empty pin
19	NC	No connection, empty pin
20	TXD	UART serial data output, 3.3V LVTTTL. One full-duplex asynchronous serial UART port is implemented. This UART output is normally used for sending position, time and velocity information from the receiver in NMEA-0183 format. When idle, this pin output HIGH.
21	RXD	UART serial data input, 3.3V LVTTTL. One full-duplex asynchronous serial UART port is implemented. This UART input is normally for sending commands or information to the receiver in SkyTraq binary protocol. In the idle condition, this pin should be driven HIGH. If the driving circuitry is powered independently of PX1125S-01, ensure that this pin is not driven to HIGH when primary power to PX1125S-01 is removed, or a 10K-ohm series resistor can be added to minimize leakage current from application to the powered off module.
22	V_BCKP	Backup supply voltage for internal RTC and backup SRAM, 1.3V ~ 3.6V. V_BCKP must be applied whenever VCC is applied. This pin should be powered continuously to minimize the startup time. If VCC and V_BCKP are both removed, the receiver will be in factory default mode upon power up, all user configuration set is lost. For applications the does not care cold starting every time, this pin can be connect to VCC.
23	VCC	Main power supply, 3.3V +/- 10%
24	GND	Ground

ELECTRICAL SPECIFICATIONS

ABSOLUTE MAXIMUM RATINGS

Parameter	Minimum	Maximum	Condition
Supply Voltage (VCC)	-0.5	3.6	Volt
Backup Battery Voltage (V_BCKP)	-0.5	3.6	Volt
Input Pin Voltage	-0.5	VCC+0.5	Volt
Input Power at RF_IN		+5	dBm
Storage Temperature	-40	+100	degC

OPERATING CONDITIONS

Parameter	Min	Typ	Max	Unit
Supply Voltage (VCC)	3	3.3	3.6	Volt
Acquisition Current (exclude active antenna current)		80		mA
Tracking Current (exclude active antenna current)		60		mA
Backup Voltage (V_BCKP)	1.3		3.6	Volt
Backup Current (VCC voltage applied)		54		uA
Backup Current (VCC voltage off)		13		uA
Output Low Voltage			0.4	Volt
Output HIGH Voltage	2.4			Volt
Input LOW Voltage			0.8	Volt
Input HIGH Voltage	2			Volt
Input LOW Current	-10		10	uA
Input HIGH Current	-10		10	uA
RF Input Impedance (RFIN)		50		Ohm

APPLICATION CIRCUIT

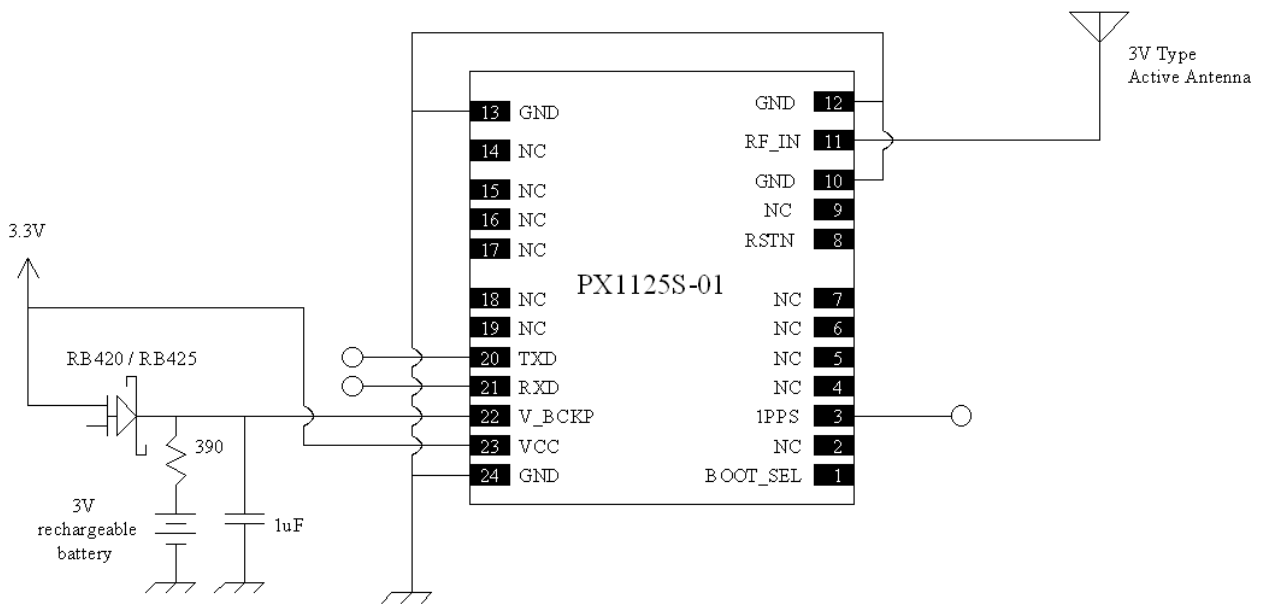

When PX1125S-01 has previously been used within 2 hour, for faster time to first fix powering up without needing to decoded ephemeris data from signal, V_BCKP should be connected to non-volatile supply; above figure with V_BCKP connected to rechargeable battery is an example implementation. If cold starting every time powering up is not an issue, V_BCKP can be connect to VCC.

PRECOMMENDED LAYOUT PAD

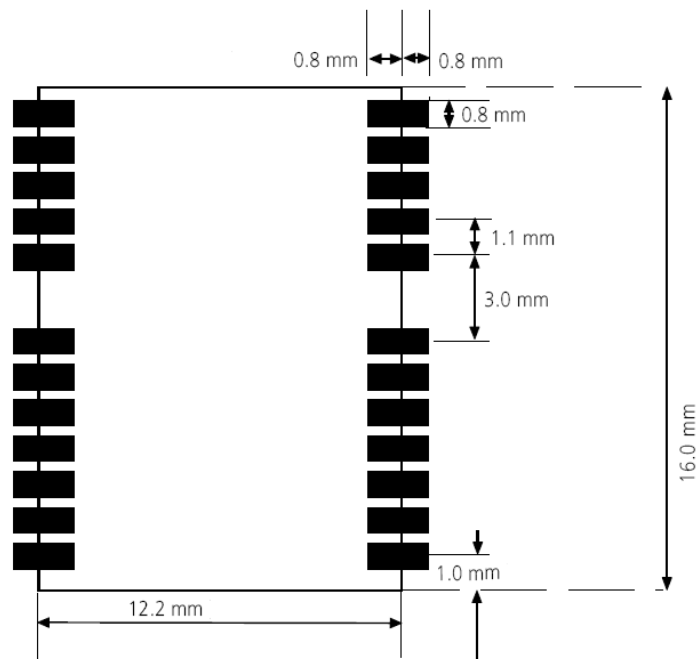

RECOMMENDED REFLOW PROFILE

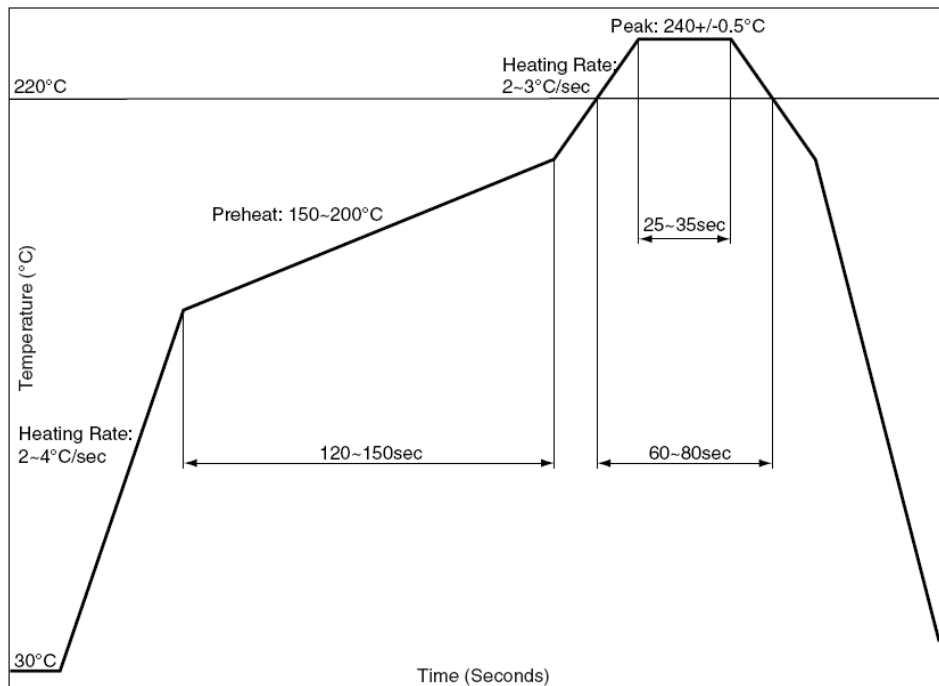

The reflow profile shown above should not be exceeded, since excessive temperatures or transport times during reflow can damage the module. Cooling temperature fall rate: max 3°C / sec

ANTENNA CONSIDERATIONS

The PX1125S-01 is designed to work with active antenna or passive antenna.

Passive ceramic patch antenna is low-cost and provides good sensitivity. 50-ohm output larger size ceramic patch antenna with higher antenna gain can be connected directly to RF input of the module. Usually the ceramic patch antenna and PX1125S-01 are mounted on opposite side of the PCB to reduce possibility of picking up digital noise. To improve signal reception performance, use larger ground plane under the patch antenna if possible; larger the ground plane, larger the overall antenna gain. The center frequency of the ceramic patch antenna changes with ground plane size. For optimal NavIC+GAGAN/GPS operation, frequency bandwidth of the antenna needs to cover 1174MHz ~ 1179MHz and 1573MHz ~ 1578MHz respectively when mounted on the PCB. It is usual to ask the ceramic patch antenna vendor to select or tune a patch antenna that best matches the customer PCB.

Active antenna is essentially a passive antenna with built-in LNA and a coaxial cable to connect the antenna to the module. It has the flexibility of being located remotely from the module, but requires antenna power. Active antenna usually costs more than passive patch antenna, but the performance in low signal environments is usually better. Active antenna with gain of 10 ~ 20dB and noise figure less than 1.5dB can be used with PX1125S-01.

Antenna Type	Passive	Active
GAGAN/GPS Frequency (MHz)	1575.42 +/- 2	1575.42 +/- 2
NavIC Frequency (MHz)	1176.45 +/- 2	1176.45 +/- 2
VSWR	< 2 (typical)	< 2 (typical)
Polarization	RHCP	RHCP
Antenna Gain	> 0dBi	> -2dBi
LNA Gain		17dB (typical)
Noise Figure		< 1.5dB
Total Gain		> 15dB

POWER SUPPLY REQUIREMENT

PX1125S-01 requires a stable power supply, avoid ripple on VCC pin (<50mVpp). Power supply noise can affect the receiver's sensitivity. Bypass capacitors of 10uF and 0.1uF is recommended to be placed close to the module VCC pin; the values could be adjusted according to the amount and type of noise present on the supply line.

BACKUP SUPPLY

The purpose of backup supply voltage pin (V_BCKP) is to keep the SRAM memory and the RTC powered when the module is powered down. This enables the module to have a faster time-to-first-fix when the module is powered on again. The backup current drain is less than 15µA. In normal powered on state, the internal processor access the SRAM and current drain is higher in active mode

1PPS OUTPUT

A 1 pulse per second signal (100msec HIGH duration) is generated on 1PPS pin when the receiver has 3D position fix using 4 or more satellites. The rising edge of the pulse is aligned with UTC second, with accuracy of about 10nsec. It outputs constant LOW when no position fix is available initially.

LAYOUT GUIDELINES

Separate RF and digital circuits into different PCB regions.

It is necessary to maintain 50-ohm impedance throughout the entire RF signal path. Try keeping the RF signal path as short as possible.

Do not route the RF signal line near noisy sources such as digital signals, oscillators, switching power supplies, or other RF transmitting circuit. Do not route the RF signal under or over any other components (including PX1125S-01), or other signal traces. Do not route the RF signal path on an inner layer of a multi-layer PCB to minimize signal loss.

Avoid sharp bends for RF signal path. Make two 45-deg bends or a circular bend instead of a single 90-degree bend if needed.

Avoid vias with RF signal path whenever possible. Every via adds inductive impedance. Vias are acceptable for connecting the RF grounds between different layers. Each of the module's ground pins should have short trace tying immediately to the ground plane below through a via.

The bypass capacitors should be low ESR ceramic types and located directly adjacent to the pin they are for.

HANDLING GUIDELINE

The PX1125S-01 modules are rated MSL4, must be used for SMT reflow mounting within 72 hours after taken out from the vacuumed ESD-protective moisture barrier bag in factory condition < 30degC / 60% RH. If this floor life time is exceeded, or if the received ESD-protective moisture barrier bag is not in vacuumed state, then the device need to be pre-baked before SMT reflow process. Baking is to be done at 85degC for 8 to 12 hours. Once baked, floor life counting begins from 0, and has 72 hours of floor life at factory condition < 30degC / 60% RH. Do not bake the module in tape-on-reel form; for baking, place parts individually onto oven tray

PX1125S-01 module is ESD sensitive device and should be handled with care.

NMEA Output Description

The output protocol supports NMEA-0183 standard. The implemented messages include GGA, GLL, GSA, GSV, VTG, RMC, and ZDA messages. The NMEA message output has the following sentence structure:

\$aacc,c-c*hh<CR><LF>

The detail of the sentence structure is explained in Table 1.

Table 1: The NMEA sentence structure

character	HEX	Description
"\$"	24	Start of sentence.
Aacc		Address field. "aa" is the talker identifier. "ccc" identifies the sentence type.
","	2C	Field delimiter.
C-c		Data sentence block.
"*"	2A	Checksum delimiter.
Hh		Checksum field.
<CR><LF>	0D0A	Ending of sentence. (carriage return, line feed)

Table 2: Overview of SkyTraq receiver's NMEA messages

\$GNGGA	Time, position, and fix related data of the receiver.
\$GNGLL	Position, time and fix status.
\$GNGSA \$GPGSA \$GIGSA	Used to represent the ID's of satellites which are used for position fix. When both GPS and NavIC satellites are used in position solution, a \$GNGSA sentence is used for GPS satellites and another \$GNGSA sentence is used for NavIC satellites. When only GPS satellites are used for position fix, a single \$GPGSA sentence is output. When only NavIC satellites are used, a single \$GIGSA sentence is output.
\$GPGSV \$GIGSV	Satellite information about elevation, azimuth and CNR, \$GPGSV is used for GPS satellites, while \$GIGSV is used for NavIC satellites
\$GNRMC	Time, date, position, course and speed data.
\$GNVTG	Course and speed relative to the ground.
\$GNZDA	UTC, day, month and year and time zone.

The formats of the supported NMEA messages are described as follows:

GGA – Global Positioning System Fix Data

Time, position and fix related data for a GNSS receiver.

Structure:

\$GNGGA,hhmmss.sss,ddmm.mmmm,a,dddmm.mmmm,a,x,xx,x.x,x.x,M,x.x,M,x.x,xxxx*hh<CR><LF>
 1 2 3 4 5 6 7 8 9 10 11 12 13

Example:

\$GNGGA,175258.000,2447.0870,N,12100.5221,E,2,15,0.7,95.2,M,19.6,M,,0000*72<CR><LF>

Field	Name	Example	Description
1	UTC Time	175258.000	UTC of position in hhmmss.sss format, (000000.000 ~ 235959.999)
2	Latitude	2447.0870	Latitude in ddmm.mmmm format Leading zeros transmitted
3	N/S Indicator	N	Latitude hemisphere indicator, 'N' = North, 'S' = South
4	Longitude	12100.5221	Longitude in dddmm.mmmm format Leading zeros transmitted
5	E/W Indicator	E	Longitude hemisphere indicator, 'E' = East, 'W' = West
6	Quality Indicator	2	Quality Indicator 0: position fix unavailable 1: valid position fix, SPS mode 2: valid position fix, differential GPS mode 3: GPS PPS Mode, fix valid 6: Estimated (dead reckoning) Mode
7	Satellites Used	15	Number of satellites in use, (00 ~ 56)
8	HDOP	0.7	Horizontal dilution of precision, (0.0 ~ 99.9)
9	Altitude	95.2	mean sea level (geoid), (-9999.9 ~ 17999.9)
10	Geoidal Separation	19.6	Geoidal separation in meters
11	Age of Differential GPS data		Age of Differential GPS data NULL when DGPS not used
12	DGPS Station ID	0000	Differential reference station ID, 0000 ~ 1023
13	Checksum	72	

GLL – Latitude/Longitude

Latitude and longitude of current position, time, and status.

Structure:

\$GNGLL,ddmm.mmmm,a,dddmm.mmmm,a,hhmmss.sss,A,a*hh<CR><LF>
1 2 3 4 5 6 7 8

Example:

\$GNGLL,2447.0870,N,12100.5221,E,175258.000,A,D*42<CR><LF>

Field	Name	Example	Description
1	Latitude	2447.0870	Latitude in ddmm.mmmm format Leading zeros transmitted
2	N/S Indicator	N	Latitude hemisphere indicator 'N' = North 'S' = South
3	Longitude	12100.5221	Longitude in dddmm.mmmm format Leading zeros transmitted
4	E/W Indicator	E	Longitude hemisphere indicator 'E' = East 'W' = West
5	UTC Time	175258.000	UTC time in hhmmss.sss format (000000.000 ~ 235959.999)
6	Status	A	Status, 'A' = Data valid, 'V' = Data not valid
7	Mode Indicator	D	Mode indicator 'N' = Data not valid 'A' = Autonomous mode 'D' = Differential mode 'E' = Estimated (dead reckoning) mode
8	Checksum	42	

GSA – GNSS DOP and Active Satellites

GNSS receiver operating mode, satellites used in the navigation solution reported by the GGA sentence and DOP values.

Structure:

```
$GNGSA,A,x,xx,xx,xx,xx,xx,xx,xx,xx,xx,xx,xx,x.x,x.x,x.x,x*hh<CR><LF>
  1 2 3 3 3 3 3 3 3 3 3 3 3 4 5 6 7 8
```

Example:

```
$GNGSA,A,3,21, 12,15,18,20,24,10,32,25,13,,,1.2,0.7,1.0,1*18<CR><LF>
$GNGSA,A,3,03,04,05,07,,,,,,,,,1.2,0.7,1.0,4*34<CR><LF>
```

Field	Name	Example	Description
1	Mode	A	Mode 'M' = Manual, forced to operate in 2D or 3D mode 'A' = Automatic, allowed to automatically switch 2D/3D
2	Mode	3	Fix type 1 = Fix not available 2 = 2D 3 = 3D
3	Satellite used 1~12	21, 12, 15, 18, 20, 24, 10, 32, 25, 13	01 ~ 32 are for GPS; 33 ~ 64 are for SBAS (PRN minus 87); 01 ~ 07 are for NavIC. GPS and NavIC satellites are differentiated by the GNSS System ID. Maximally 12 satellites are included in each GSA sentence.
4	PDOP	1.2	Position dilution of precision (0.0 to 99.9)
5	HDOP	0.7	Horizontal dilution of precision (0.0 to 99.9)
6	VDOP	1.0	Vertical dilution of precision (0.0 to 99.9)
7	GNSS System ID	1	1 for GPS, 4 for NavIC
8	Checksum	18	

GSV – GNSS Satellites in View

Number of satellites (SV) in view, satellite ID numbers, elevation, azimuth, and SNR value. Four satellites maximum per transmission.

Structure:

```
$GPGSV,x,x,xx,xx,xx,xxx,xx,...,xx,xx,xxx,xx,x *hh<CR><LF>
  1 2 3 4 5 6 7 4 5 6 7 8 9
```

Example:

```
$GPGSV,4,1,13,02,72,109,43,24,69,035,48,18,52,330,42,21,49,246,43,1*69<CR><LF>
$GPGSV,4,2,13,20,47,118,42,15,39,046,44,41,39,242,41,12,28,129,42,1*68<CR><LF>
$GPGSV,4,3,13,10,25,321,38,25,15,170,35,32,14,278,36,13,06,063,35,1*64<CR><LF>
$GPGSV,4,4,13,05,04,126,36,1*57<CR><LF>
$GIGSV,2,1,07,07,63,158,46,05,61,202,44,04,57,199,44,03,39,243,42,4*7F<CR><LF>
$GIGSV,2,2,07,01,00,000,39,02,00,000,24,06,00,266,,4*44<CR><LF>
```

Field	Name	Example	Description
1	Number of message	4	Total number of GSV messages to be transmitted (1-5)
2	Sequence number	1	Sequence number of current GSV message
3	Satellites in view	13	Total number of satellites in view (00 ~ 20)
4	Satellite ID	02	01 ~ 32 are for GPS; 33 ~ 64 are for SBAS (PRN minus 87); 01 ~ 07 are for NavIC. GPS and NavIC satellites are differentiated by the GNSS System ID. Maximally 4 satellites are included in each GSV sentence.
5	Elevation	72	Satellite elevation in degrees, (00 ~ 90)
6	Azimuth	109	Satellite azimuth angle in degrees, (000 ~ 359)
7	SNR	43	C/No in dB (00 ~ 99) Null when not tracking
8	GNSS System ID	1	1 for GPS, 4 for NavIC
9	Checksum	69	

RMC – Recommended Minimum Specific GNSS Data

Time, date, position, course and speed data provided by a GNSS navigation receiver.

Structure:

\$GNRMC,hhmmss.sss,A,dddmm.mmmm,a,dddmm.mmmm,a,x.x,x.x,ddmmy,,a*hh<CR><LF>
 1 2 3 4 5 6 7 8 9 10 11

Example:

\$GNRMC,175258.000,A,2447.0870,N,12100.5221,E,000.0,000.0,220617,,,D*75<CR><LF>

Field	Name	Example	Description
1	UTC time	175258.000	UTC time in hhmmss.sss format (000000.00 ~ 235959.999)
2	Status	A	Status 'V' = Navigation receiver warning 'A' = Data Valid
3	Latitude	2447.0870	Latitude in dddmm.mmmm format Leading zeros transmitted
4	N/S indicator	N	Latitude hemisphere indicator 'N' = North 'S' = South
5	Longitude	12100.5221	Longitude in dddmm.mmmm format Leading zeros transmitted
6	E/W Indicator	E	Longitude hemisphere indicator 'E' = East 'W' = West
7	Speed over ground	000.0	Speed over ground in knots (000.0 ~ 999.9)
8	Course over ground	000.0	Course over ground in degrees (000.0 ~ 359.9)
9	UTC Date	220617	UTC date of position fix, ddmmyy format
10	Mode indicator	D	Mode indicator 'N' = Data not valid 'A' = Autonomous mode 'D' = Differential mode 'E' = Estimated (dead reckoning) mode
11	checksum	75	

VTG – Course Over Ground and Ground Speed

The actual course and speed relative to the ground.

Structure:

GNVTG,x.x,T,,M,x.x,N,x.x,K,a*hh<CR><LF>
 1 2 3 4 5

Example:

\$GNVTG,000.0,T,,M,000.0,N,000.0,K,D*16<CR><LF>

Field	Name	Example	Description
1	Course	000.0	True course over ground in degrees (000.0 ~ 359.9)
2	Speed	000.0	Speed over ground in knots (000.0 ~ 999.9)
3	Speed	000.0	Speed over ground in kilometers per hour (000.0 ~ 1800.0)
4	Mode	D	Mode indicator 'N' = Data not valid 'A' = Autonomous mode 'D' = Differential mode 'E' = Estimated (dead reckoning) mode
5	Checksum	16	

ZDA – TIME AND DATE

UTC, day, month, year and local time zone

Structure:

\$GNZDA,hhmmss.sss,xx,xx,xxxx,xx,xx*hh<CR><LF>
 1 2 3 4 5 6 7

Example:

\$GNZDA,175258.000,22,06,2017,00,00*46<CR><LF>

Field	Name	Example	Units	Description
1	UTC time	175258.000		UTC time in hhmmss.ss format (000000.00 ~ 235959.99)
2	UTC Day	22		UTC time: day (01 ~ 31)
3	UTC Month	06		UTC time: month (01 ~ 12)
4	UTC Year	2017		UTC time: year (4 digit format)
5	Local zone hour	00		Local zone hours (00 ~ +/- 13)
6	Local zone minutes	00		Local zone minutes (00 ~59)
7	Checksum	46		Checksum

Data Type Definition

UINT8	8 bit unsigned integer
UINT16	16 bit unsigned integer
UINT32	32 bit unsigned integer
SINT8	8 bit signed integer
SINT16	16 bit signed integer
SINT32	32 bit signed integer
SPFP	32 bit single precision floating point number
DPFP	64 bit double precision floating point number

ORDERING INFORMATION

Model Name	Description
PX1125S-01	NavIC + GAGAN/GPS Receiver Module
PX1125S-01A	Crystal Oscillator + Temperature Sensor Version of PX1125S-01 for TCXO Shortage Period
PX1125S-01C	PX1125S-01 with additional GAGAN Messaging Type 63 Support

Revision History

Revision	Date	Description
1	December 12, 2019	Initial release
2	March 18, 2020	Operational limit updated
3	May 22, 2020	Current consumption updated
4	January 28, 2021	Updated ordering information
5	February 22, 2021	Updated current consumption numbers
6	April 13, 2021	Added GAGAN Sub-Frame Message Type 63 Output

The information provided is believed to be accurate and reliable. These materials are provided to customers and may be used for informational purposes only. No responsibility is assumed for errors or omissions in these materials, or for its use. Changes to specification can occur at any time without notice.

These materials are provided "as is" without warranty of any kind, either expressed or implied, relating to sale and/or use including liability or warranties relating to fitness for a particular purpose, consequential or incidental damages, merchantability, or infringement of any patent, copyright or other intellectual property right. No warrant on the accuracy or completeness of the information, text, graphics or other items contained within these materials. No liability assumed for any special, indirect, incidental, or consequential damages, including without limitation, lost revenues or lost profits, which may result from the use of these materials.

The product is not intended for use in medical, life-support devices, or applications involving potential risk of death, personal injury, or severe property damage in case of failure of the product.